



Betriebsanleitung

Dampflokomotive mit Schlepptender BR 53⁸ Württembergische Klasse Fc 624 H0



Die Geländeverhältnisse in Württemberg erforderten schon früh starke Lokomotiven. Bereits 1849 entstand bei der Maschinenfabrik Esslingen der erste Dreikuppler der „Alb“-Klasse. Die fünf zugkräftigen Loks sollten den steilen Alaufstieg meistern. Mit ihrer unbändigen Kraft und ihrem enormen Gewicht beeindruckten sie gewaltig und waren ihrer Zeit weit voraus: Sie zerstörten die damals noch schwachen Schienen. Ab 1864 beschafften die Königlich Württembergischen Staats Eisenbahnen K.W.St.E. die dreifach gekuppelten Loks als Klasse F in großem Stil. Die Bauart wurde dabei kontinuierlich weiterentwickelt. So entstand nach der Klasse F2 schließlich 1889 die letzte und bedeutendste Vertreterin, die Klasse Fc. 1890 lieferte die Maschinenfabrik Esslingen das erste Exemplar der Klasse Fc. Die Fc beförderte einen Zug von 1000 t in der Ebene mit einer Geschwindigkeit von 45 km/h. Dies entsprach der damals vorgeschriebenen Höchstgeschwindigkeit für Güterzüge. Auf einer Steigung von 10 % waren es noch 379 t mit 25 km/h. Bis 1909 wurden 125 Exemplare der Fc beschafft. Damit bildete sie die wichtigste Stütze des württembergischen Güterzugdienstes. Die Deutsche Reichsbahn übernahm 65 Lokomotiven und reihe sie als 53 801 bis 53 865 in ihren Bestand ein. 1931 wurden die kleinen Maschinen ausgemustert.





BR 53⁸ – H0

Steam engine with trailing tender BR 53⁸ Württemberg class Fc – H0

The Württemberg terrain made strong locomotives a necessity very early on. In 1849, the first treble shunter of the "Alb" class was created at the machine factory in Esslingen. The five strong locomotives were intended to master the steep climb up the Alb. Their great power and enormous weight was very impressive and they were way ahead of their time. They destroyed the railway tracks which were still weak then. From 1864, the Royal State of Württemberg Railways K.W.St.E. purchased many of these triple shunter locomotives as class F. The construction was continuously developed further. Finally in 1889 after the class F2, the final and most important of this series was created, the Fc. The Fc could transport a train weighing 1000 t on flat terrain at a speed of 45 km/h which was the highest speed allowed for freight trains. On a slope of 10%, it could transport 379 t at 25 km/h. By 1909, 125 Fcs had been purchased. They formed the most important base of the Württemberg freight service. The German Reichsbahn took over 65 locomotives and gave them the numbers 53 801 up to 53 865. In 1931, the small locomotives were taken out of service.



Nicht bestimmt für Kinder unter 3 Jahren. Verschluckbare Kleinteile. Betriebsanleitung aufbewahren!
Not recommended for children under 3 years of age. Small parts may be swallowed. Retain the operating instructions!



Zum Betrieb des vorliegenden Produkts darf als Spannungsquelle nur ein nach VDE 0551/EN 60742 gefertigter Spielzeug-Transformator verwendet werden.
Only a toy transformer produced compliant with VDE 0551/EN 60742 may be used as a voltage source to operate this product.



Dieses Produkt entspricht den grundlegenden Sicherheits- und Gesundheitsanforderungen der Europäischen Richtlinie für Spielzeuge (88/378/EWG) unter Beachtung der Europäischen Sicherheitsnorm EN 71.
This product conforms to the fundamental health and safety requirements of the European Directive for Toys (88/378/EEC) with due regard to the European Safety Standard EN 71.



Elektro- und Elektronikaltgeräte dürfen nicht in den Hausmüll gelangen. Sie müssen entsprechend der jeweils gültigen Länderrichtlinien fachgerecht entsorgt werden.



Electrical equipment may not reach to domestic waste. According to the current terms of the country reference the electrical equipment must professional disposed.





Inhaltsverzeichnis Contents



Benennung	Seite
Allgemeine Montage- und Sicherheitshinweise	3, 4
Entnahme der Lok aus der Verpackung	5
Zusatzbauteile montieren	6
Wartungsarbeiten	
Lokomotive	
• 1. Ölen	7
• 2. Gehäuse demontieren	8,9
• 3. Motor tauschen	8,9
• 4. Glühbirnenwechsel	8,9
• 5. Schleifer tauschen bei Wechselstrom-Ausführung	8,9
• 6. Wartungsarbeiten am oberen Getriebeteil	8,9
• 7. Wartungsarbeiten am Kupplungsnormschacht	8,9
Hinweis für weitere Wartungsarbeiten	8,9
Tender	
• 8. Tender demontieren	10,11
• 9. Platiene tauschen	10,11
• 10. Premium-Digitaldecoder tauschen bei AC Ausf.	10,11
• 11. Glühbirnenwechsel	10,11
• 12. Wartungsarbeiten am Kupplungsnormschacht	10,11
• 13. Umrüsten auf Digitalbetrieb	10,11
Ersatzteilliste	
Gleichstrom- und Wechselstrom-Ausführung	16 – 20
Bestellbeispiel	20
Allgemeine Montage- und Sicherheitshinweise	
• Diese Bedienungsanleitung beschreibt sämtliche Arbeitsvorgänge die zur Wartung und Instandhaltung notwendig sind. Bitte lesen Sie diese Bedienungsanleitung bevor Sie mit den Arbeiten beginnen.	
• Bei unsachgemäßem Umgang mit elektrischen Bauteilen können diese zerstört werden. Für entsprechende Arbeiten (z.B. Platin-enwechsel) können Sie sich an Ihren Fachhändler oder den Hersteller wenden.	
• Bei den folgenden Wartungsarbeiten ist die jeweilige Demontage beschrieben, der Zusammenbau ist in umgekehrter Reihenfolge auszuführen.	





Inhaltsverzeichnis

Contents

- Die folgenden Wartungsarbeiten sind bei Gleich- und Wechselstrom-Ausführungen fast identisch. Im Ausnahmefall wird im entsprechenden Textabschnitt Bezug genommen.
- Achten Sie beim Zerlegen der Lokomotive auf die Einbaulage der entsprechenden Bauteile. Wird ein Bauteil falsch eingebaut kann dieses zerstört werden oder es kommt zu Funktionsstörungen im Betrieb.

Description	Page
General assembly and safety information	5
Removing the locomotive from the packaging	5
Fitting additional parts	6
Maintenance works	
Locomotive	
• 1. Lubricating	7
• 2. Dismantling the housing	12, 13
• 3. Exchanging the motor	12, 13
• 4. Exchanging the bulb	12, 13
• 5. Exchanging the sliding contact of the Alternating Current Version	12, 13
• 6. Maintenance work on the upper transmission section	12, 13
• 7. Maintenance work on the front standard coupling shaft	12, 13
Note maintenance works	12, 13
Tender	
• 8. Dismantling the tender	14, 15
• 9. Exchanging the circuit board	14, 15
• 10. Exchanging the premium digital decoder	14, 15
• 11. Exchanging the bulb	14, 15
• 12. Maintenance work on the standard coupling shaft ..	14, 15
• 13. Converting for digital operation	14, 15
Spare parts list	
Direct current and alternating current	16 – 20
Order example	20





General assembly and safety information

- These operating instructions describe all work steps necessary for maintenance and repair. Please read these operating instructions carefully before you start with your work.
- In the case of incorrect handling of electrical components, they may be destroyed. Please ask your specialist dealer to help with the necessary work (e.g. changing circuit boards).
- In the case of maintenance work, the disassembly is described below, to re-assemble the tractor reverse the work steps.
- The maintenance work described below is virtually identical for direct current and alternating current models. If there are any differences these will be pointed out specifically.
- When dismantling the engine make a note of the mounted position of the individual parts. An incorrectly mounted part can be destroyed or operation can be disrupted.

Arbeiten vor der Inbetriebnahme Work to be performed before starting up



Entnahme der Lok aus der Verpackung (Fig. 1)

Deckel der Verpackung öffnen. Kunststoff-Schutzverpackung mit Lok entnehmen und auf einen Tisch oder ähnliches abstellen. Lasche (1) lösen, Deckel und Seitenteile der Schutzverpackung wegklappen, Lok entnehmen und Transportsicherung (2) entfernen.



Withdrawal of Engine from Packaging (Fig. 1)

Open package lid. Take out plastics protecting package with engine and put it down on a table or similar item. Loosen latch (1), fold away lid and side parts of protecting package, take out engine and take out engine and remove the transport safety device (2).

Fig. 1

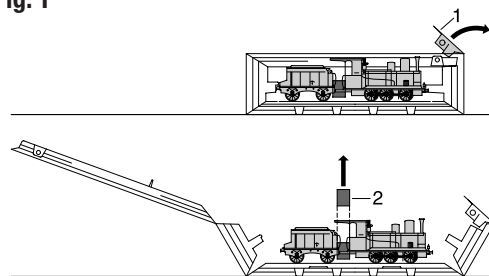

5





Arbeiten vor der Inbetriebnahme Work to be performed before starting up

Zusatzbauteile montieren (Fig. 2)

In der Verpackung sind zusätzliche Bauteile lose beigelegt.

- 1 = 2 x Bügelkupplung
- Werden die Bauteile aus dem Zurüstbeutel für Vitrinenmodelle montiert, ist die Lok nicht mehr für den Fahrbetrieb geeignet.
 - 2 = 2 x Bremsschlauch rechts, Knorr
 - 3 = 2 x Bremsschlauch links, Knorr
 - 4 = 2 x Bremsschlauch rechts, Westinghouse
 - 5 = 2 x Bremsschlauch links, Westinghouse
 - 6 = 2 x Kupplungsimitat
 - 7 = 1 x Schienenräumer

Fitting additional parts (Fig. 2)

Accessory parts have been loosely enclosed in the packaging.

- 1 = 2 x Bow coupling
- If the components from the add-on bag for display models are mounted, then the engine will no longer be suitable for operation.
 - 2 = 2 x Air-brake hose right, Knorr
 - 3 = 2 x Air-brake hose left, Knorr
 - 4 = 2 x Air-brake hose right, Westinghouse
 - 5 = 2 x Air-brake hose left, Westinghouse
 - 6 = 2 x Imitation coupling
 - 7 = 1 x Chassis cover dummy



Fig. 2

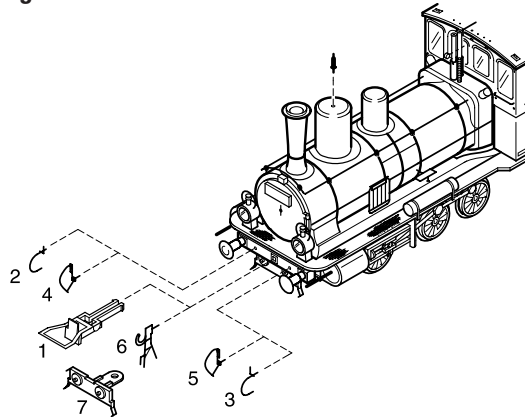

6





Wartungsarbeiten Maintenance works



1. Ölen (Fig. 3)

Der Motor und die Lagerstellen der Radsätze können an den gekennzeichneten Punkten sparsam mit Öl der Modellbaubranche geölt werden. Zum Ölen des Motors ist das Gehäuse abzunehmen, siehe Seite 8 Punkt 2.

1. Lubricating (Fig. 3)

The engine and the wheelset bearings may be sparingly lubricated at the marked places with oil used for model making purposes.

In order to lubricate the engine, remove the housing, compare page 12, item 2.

Fig. 3

Motor
Motor

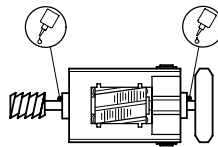

Räder
Wheels

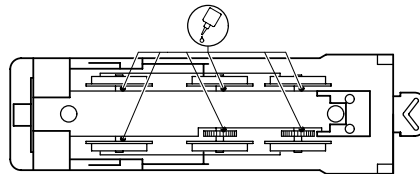



Wartungsarbeiten an der Lok

2. Gehäuse demontieren (Fig. 4)

3 Schrauben (1 und 2) an der Gehäuseunterseite herausdrehen und Gehäuse (3) am Führerhaus leicht eindrücken – Clip an der Unterseite lösen – und nach oben abnehmen.

3. Motor tauschen (Fig. 4)

Gehäuse abnehmen, siehe Punkt 2.
Befestigungsschrauben (4) herausdrehen, Schneckenabdeckung (5) abnehmen. Motor (6) nach oben herausziehen.
Verkabelung am Motor (7) ablöten.

Hinweis:

Beim Ausbau des Motors muss auf die Verkabelung geachtet werden – sonst falsche Fahrtrichtung.

4. Glühbirnenwechsel (Fig. 4)

Gehäuse abnehmen, siehe Punkt 2.
Abdeckung (8) der Kupplung von der Bodenplatte (9) abclipsen. Bodenplatte (9) nach oben abnehmen. Isolierungen (10) an den Kabeln zurückziehen und Glühbirne (11) ablöten.
Neue Glühbirne entsprechend anlöten und die Isolierungen wieder über die Lötstelle ziehen.



5. Schleifer tauschen bei Wechselstrom-Ausführung (Fig. 4)

Befestigungsschraube (12) herausdrehen, Schleifer (13) abnehmen.



6. Wartungsarbeiten am oberen Getriebeteil (Fig. 4)

Gehäuse und Motor demontieren, siehe Punkt 2 und 3.
Befestigungsschraube (14) herausdrehen, Getriebeabdeckung (15) nach oben abnehmen.
Das Zahnrad (16) kann von oben entnommen werden.

7. Wartungsarbeiten am vorderen Kupplungs-normschacht (Fig. 4)

Befestigungsschraube (2) herausdrehen, Kupplungsnormschacht (17) nach vorne abnehmen.

Hinweis für weitere Wartungsarbeiten:

Bei Wartungsarbeiten an den Radsätzen (18), dem Kuppelgestänge (19) oder dem Getriebe muss die untere Getriebeabdeckung (20) durch Herausdrehen der Schrauben (21) abgenommen werden. Wir bitten Sie bei der Demontage des Fahrgestells genau darauf zu achten, wo und wie jedes Einzelteil montiert war. Die Einbaulage können Sie auch aus der Ersatzteilgrafik auf Seite 16 entnehmen.





Fig. 4

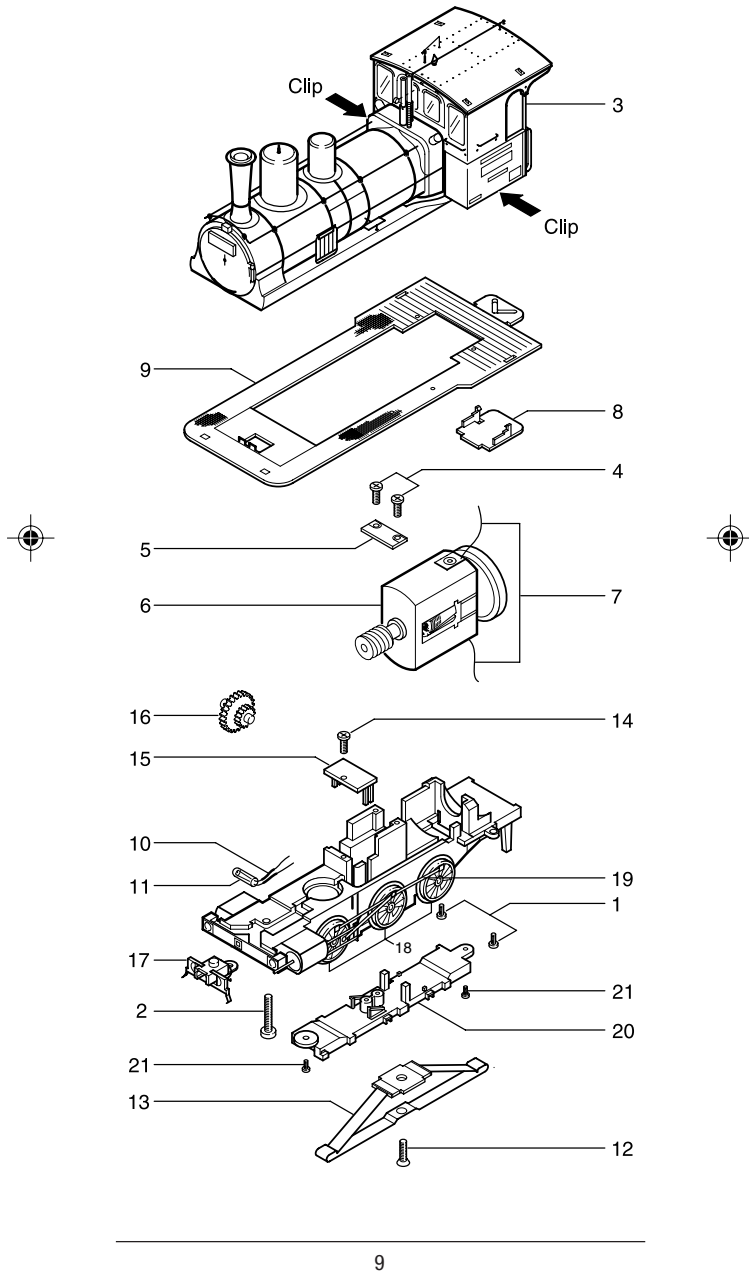



Wartungsarbeiten am Tender

8. Tender demontieren (Fig. 5)

Schraube (22) herausdrehen, Fahrgestell (23) abnehmen. Gehäusedeckel (24) nach oben abnehmen und Gehäuse (25) vom Gewichtblock (26) abziehen.

9. Platine tauschen (Fig. 5)

Tender demontieren, siehe Punkt 8. Blindstecker (27) bei DC-Ausführung oder Premium-Digitaldecoder (28) bei AC-Ausführung abziehen. Befestigungsschrauben (29) herausdrehen, Platine (30) nach oben abnehmen. Steckverbindung (31) trennen. Einbau der neuen Platine in umgedrehter Reihenfolge vornehmen.

10. Premium-Digitaldecoder tauschen bei Wechselstrom Ausführung (Fig. 5)

Tender demontieren, siehe Punkt 8. Premium-Digitaldecoder (28) abziehen und neuen einstecken.

11. Glühbirnenwechsel (Fig. 5)

Tender demontieren, siehe Punkt 8. Glühbirne (32) von der Platine (30) ablöten, neue Glühbirne anlöten.

12. Wartungsarbeiten am Kupplungsnormschacht (Fig. 5)

Tender demontieren, siehe Punkt 8. Normschachthalter (33) ausclipsen und mit Kupplungsnormschacht (34) entnehmen.

13. Umrüsten und Umprogrammieren auf Digitalbetrieb (Fig. 5)

Wechselstrom-Ausführung

Lokomotiven in Wechselstrom-Ausführung AC werden serienmäßig mit Premium-Digitaldecoder (28) ausgeliefert. Der Decoder erkennt die Betriebsart (analog/digital) selbstständig. Soll der Decoder umprogrammiert werden, liegt die Einbau- und Betriebsanleitung Premium-Digitaldecoder bei.

Der Decoder ist werkseitig auf Adresse 03 eingestellt.

Gleichstrom-Ausführung

Tender demontieren, siehe Seite 10, Punkt 8. Blindstecker (27) abziehen und Digitaldecoder einstecken. **Den richtigen Einbau des Digitaldecoders, dessen Einsteckrichtung und Programmierung entnehmen Sie der Betriebsanleitung des Decoderherstellers.** Nach Einstecken des Digitaldecoders ist die Funktion des Lichtes zu prüfen. Wenn keine Lichtfunktion – Stecker um 180° drehen.

Hinweis:

Wir bitten Sie genau darauf zu achten, wo und wie jedes Einzelteil montiert war. Die Einbaulage können Sie auch aus der Ersatzteilgrafik Seite 17 entnehmen.





Fig. 5

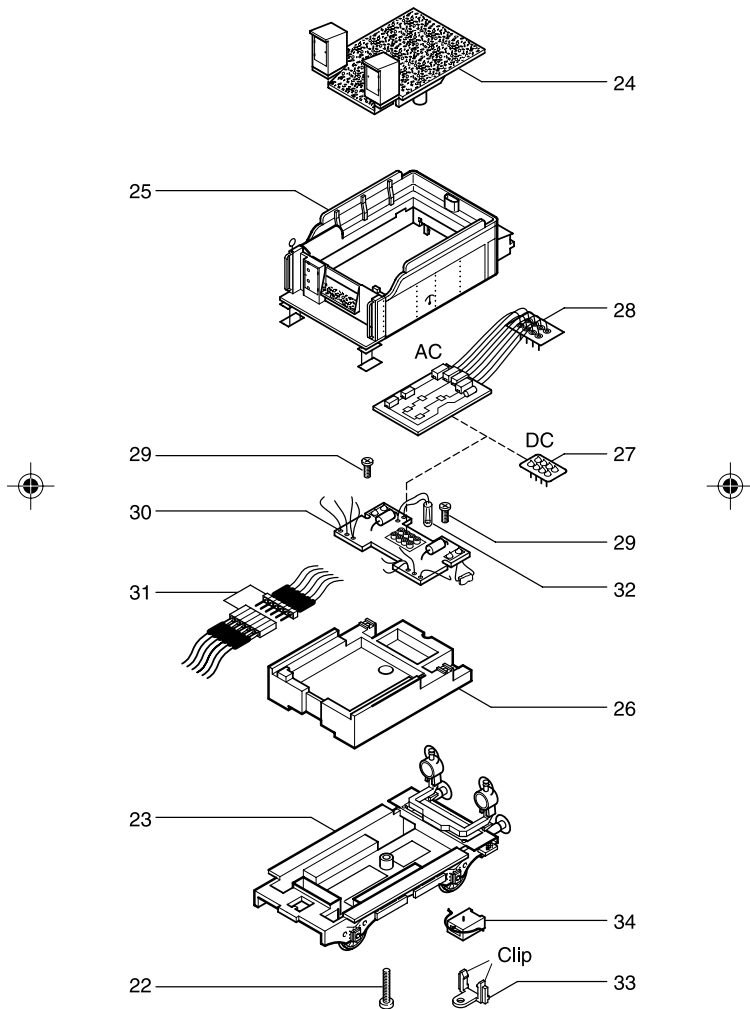



Maintenance works on the loco

2. Dismantling the housing (Fig. 4)

Unscrew the 3 screws (1 and 2) on the housing underside and slightly push in the housing (3) at the driver's cab – release clip on the underside – and remove to the top.

3. Exchanging the motor (Fig. 4)

Remove the housing; see item 2.
Unscrew the fastening screws (4). Detach the worm cover (5). Lift out the motor (6). Unsolder the cabling on the motor (7).

Note:

Pay attention to the cabling when removing the motor, otherwise the travelling direction will be wrong.

4. Exchanging the bulb (Fig. 4)

Remove the housing; see item 2.
Clip coupling cover (8) off the base plate (9). Remove base plate (9) to the top. Pull back insulation (10) from the cables and unsolder the bulb (11). Solder a replacement bulb in place accordingly and pull the insulation back over the soldering joint.

5. Exchanging the sliding contact of the alternating current version (Fig. 4)

Unscrew the fastening screw (12).
Remove the sliding contact (13).

6. Maintenance work on the upper part of the gearing (Fig. 4)

Dismantle the housing and the motor; see items 2 and 3. Unscrew the fastening screw (14), remove the gearbox cover (15) to the top. The gear wheel (16) can be lifted out from above.

7. Maintenance work on the front standard coupling shaft (Fig. 4)

Unscrew the fastening screw (2), remove standard coupling shaft (17) to the front.

Note maintenance works:

The bottom gearbox cover (20) must be removed by unscrewing the screws (21) to carry out maintenance work on the wheel sets (18), the coupling rods (19) or the gearing.

When dismantling the bogie, please note exactly where each individual part was mounted. The mounting position is also indicated on the spare parts graph on page 16.





Fig. 4

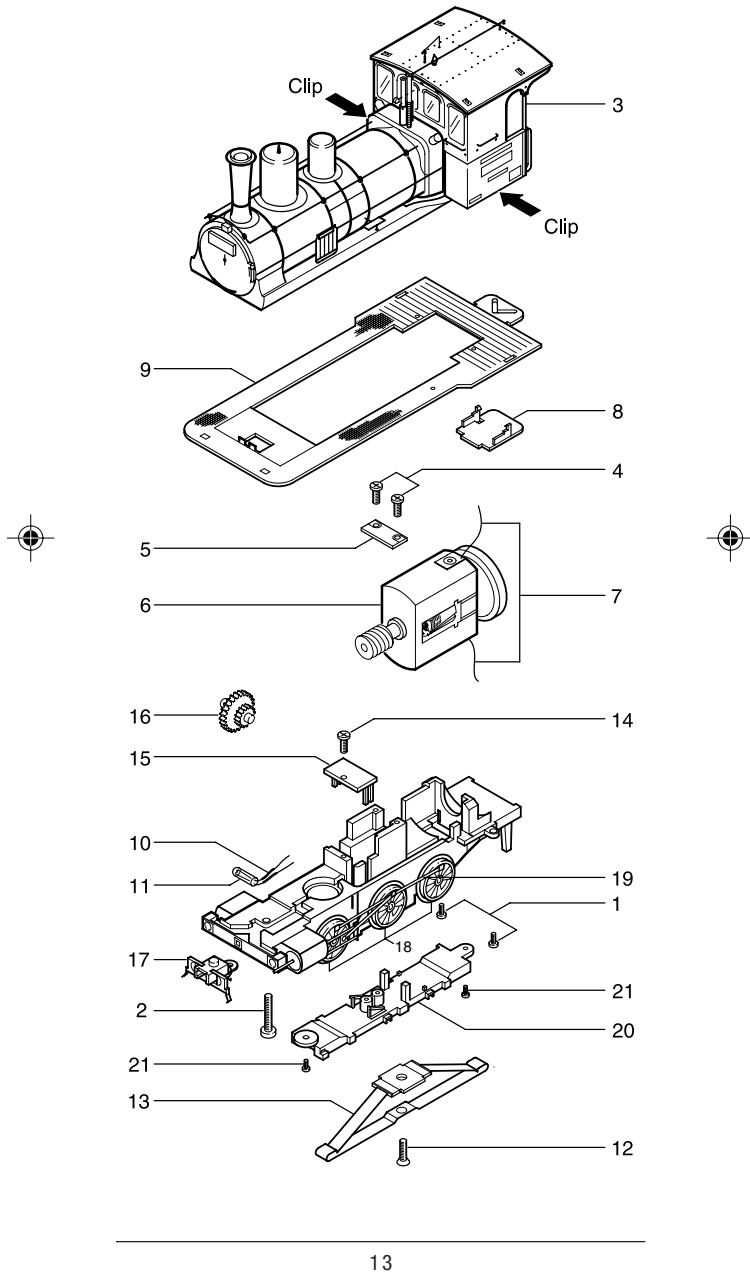



Maintenance works on the tender

8. Dismantling the tender (Fig. 5)

Unscrew the screw (22) and remove the bogie (23).
Remove the housing cover (24) to the top and pull housing (25) off the weight block (26).

9. Exchanging the circuit board (Fig. 5)

Dismantle the tender; see item 8. Pull off the dummy plug (27) of the DC version, or the digital decoder (28) of the AC version.
Unscrew the fastening screws (29), remove the circuit board (30) to the top. Separate plug-connection (31).
Mount the replacement circuit board in reverse order.

10. Exchanging the premium digital decoder of the alternating current version (Fig. 5)

Dismantle the tender; see item 8. Pull off the premium digital decoder (28) and plug in replacement.

11. Exchanging the bulb (Fig. 5)

Dismantle the tender; see item 8. Unsolder the bulb (32) from the circuit board (30), solder a replacement bulb in place.

12. Maintenance work on the standard coupling shaft (Fig. 5)

Dismantle tender; see item 8. Clip off standard shaft mounting (33) and remove together with standard coupling shaft (34).

13. Retrofitting and reprogramming to digital operation (Fig. 5)

Alternating current version

The premium digital decoder (28) is standard for the alternating current (AC) locomotives models. The decoder independently identifies the operation type (analog/digital). Please refer to the enclosed installation and operation instructions "Premium Digital Decoder" in the event that the decoder needs to be reprogrammed.

The decoder is set to address 03 in the factory.

Direct current version

Dismantle the tender; see page 10, item 8. Pull off the dummy plug (27) and plug in the digital decoder. **For the correct installation of the digital decoder, the direction in which to plug it in and how to programme it, please refer to the mounting instructions of the decoder manufacturer.** Once the digital decoder has been plugged in, it must be checked whether the light is working. If the light does not function, turn the plug by 180°.

Note:

Please note exactly where and how each individual part was mounted. The mounting position is also indicated on the spare parts graph on page 17.





Fig. 5

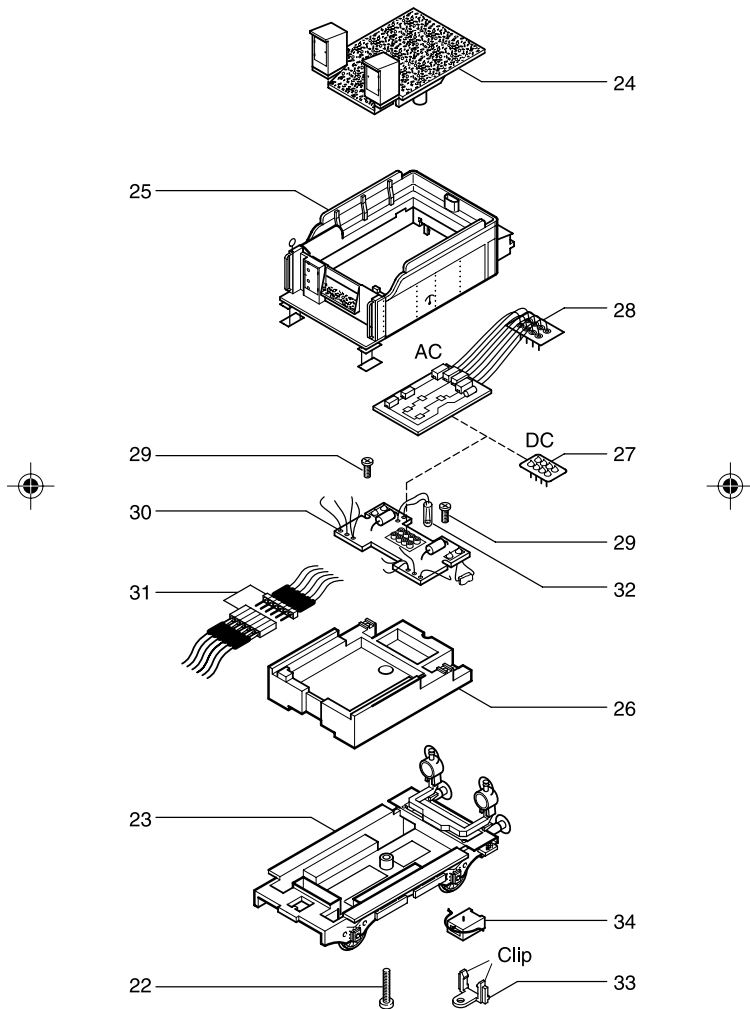



Ersatzteilliste Lokomotive BR 53 Spare Parts List locomotive BR 53

Gleichstrom / Wechselstrom D.C.current / A.C. current

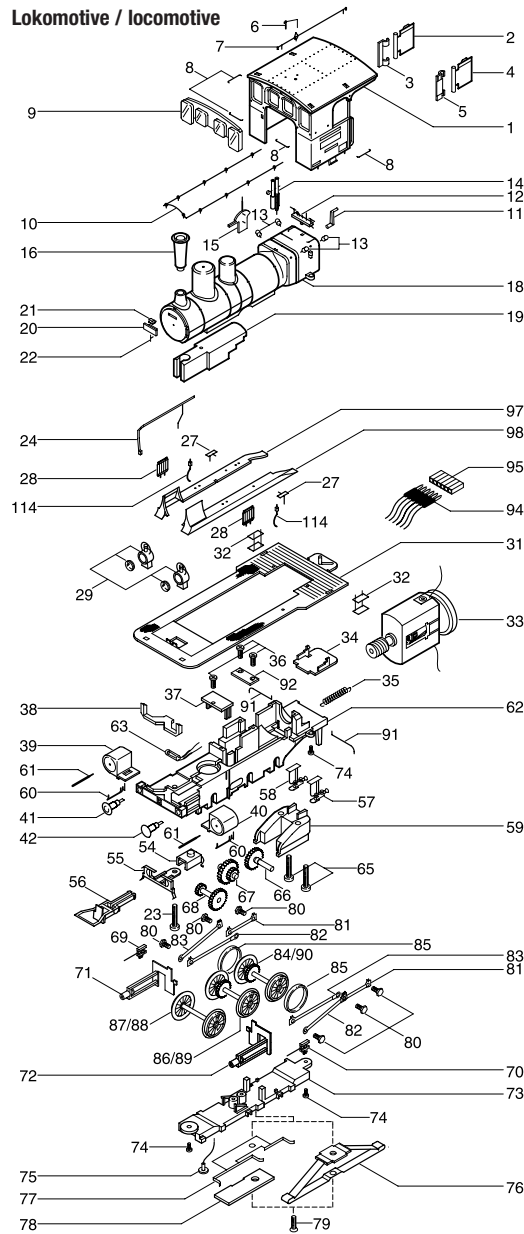

16





Gleichstrom / Wechselstrom

D.C.current / A.C. current

Tender / Tender

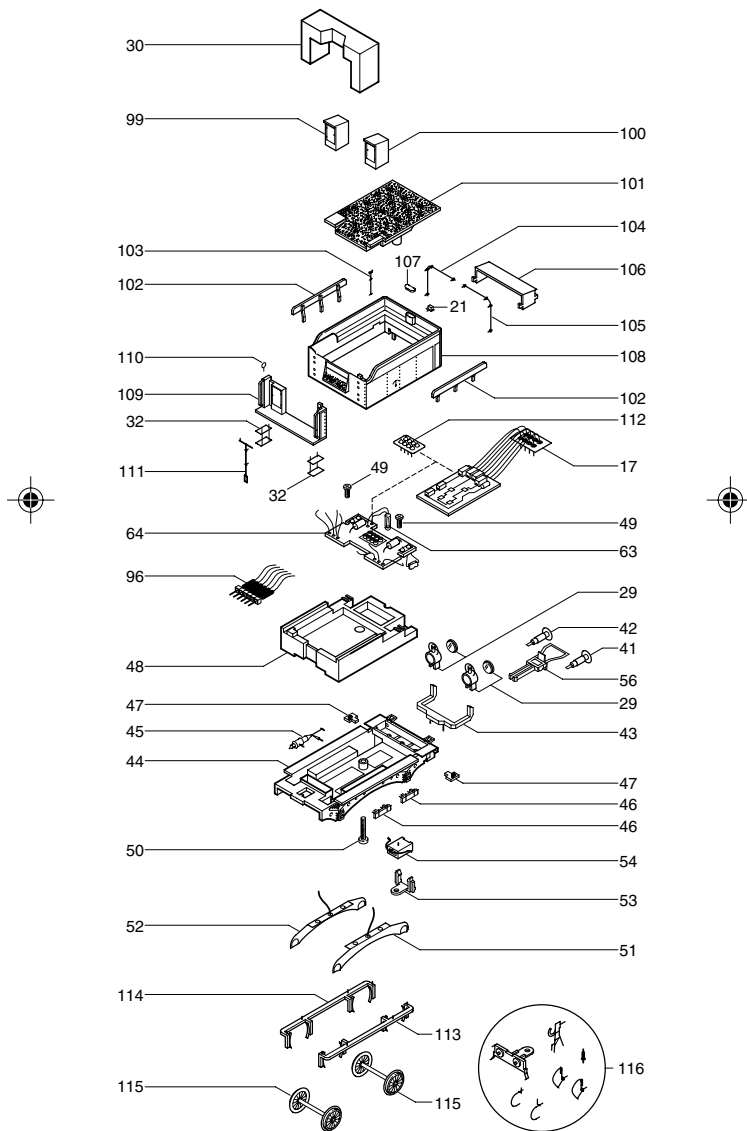



Ersatzteilliste BR 53 Spare Parts List BR 53

Pos.	Bestell Nr. Order no.	Benennung	Description
001	40052.50.01	Führerhaus	Drivers cabin
002	40052.50.02	Türe rechts	Door right
003	40052.50.03	Türhalter rechts	Door holder right
004	40052.50.04	Türe links	Door left
005	40052.50.05	Türhalter links	Door holder left
006	0600.99.01	Pfeife Führerhaus	Whistle
007	0620.50.07	Notseil	Emergency rope
008	0620.50.08	Griff Führerhaus	Handrail
009	0620.50.09	Fenster Führerhaus	Window
010	0620.50.10	Griffstange Kessel	Handrail boiler
011	0620.50.11	Reglerhebel	Regulator
012	0620.50.12	Armaturen	Fitting
013	0620.50.13	Waschlücke	Cleaning hatch
014	0620.50.14	Sicherheitsventil	Safety valve
015	0620.50.15	Umsteuerungshebel	Reversing handle
016	0620.50.16	Schornstein	Chimney
017**	9750	Premium-Digitaldecoder	Premium digital decoder
018	40052.50.18	Kessel	Boiler
019	0620.50.19	Kesselgewicht	Weight for boiler
020	40052.50.20	Lokschild	Number plate
021	0620.50.21	Signalhalter	Signal holder
022	0620.50.22	Knebel f. Rauchkammer	Smoke box dart
023	0620.50.23	Schraube f. Gewicht	Screw for weight
024	0620.50.24	Umsteuerstange	Reversing rod
027	40052.50.27	Trittstufe Umlauf	Step
028	0620.50.28	Zentralschmierung	Central oiling unit
029	0620.50.29	Lampe mit Glas	Lamp with glass
030	0620.50.30	Transportsicherung	Transport lock
031	40052.50.31	Umlauf	Walkway
032	40052.50.32	Aufstieg	Step
033	0620.50.33	Motor kpl.	Motor cpl.
034	0620.50.34	Abdeckung	Cover
035	0620.50.35	Feder	Spring
036	0620.50.36	Schraube	Screw
037	0620.50.37	Getriebekapselung	Upper gearbox cover
038	0620.50.38	Lichtleiter vorn	Light bar front
039	0620.50.39	Zylinder rechts	Cylinder right
040	0620.50.40	Zylinder links	Cylinder left
041	0620.50.41	Puffer gewölbt	Buffer round
042	0620.50.42	Puffer flach	Buffer flat
043	0620.50.43	Lichtleiter hinten	Light bar rear
044	40052.50.44	Tenderrahmen	Tender frame
046	0620.50.46	Hebewinde	Winch
047	40052.50.47	Tritt Tender	Step
048	0620.50.48	Tendergewicht	Weight for tender
049	0620.50.49	Platinenschraube	Screw circuit board
050	0620.50.50	Tenderschraube	Screw tender
051	0620.50.51	Stromabnehmer Tender links	Pick up tender left
052	0620.50.52	Stromabnehmer Tender rechts	Pick up tender right
053	40052.50.53	Normschachthalter	Coupler pocket cover
054	0560.99.32	Normschacht	Coupler pocket

* Bauteil wird nur bei Gleichstrom-Ausführung verwendet.

** Bauteil wird nur bei Wechselstrom-Ausführung verwendet.





055	40052.50.55	Schienenräumer	Chassis cover working part
056	9952.50.03	Bügelkupplung	Bow coupling
057	40052.50.57	Wassertrompete links	Water input left
058	40052.50.58	Wassertrompete rechts	Water input right
059	0620.50.59	Aschekasten	Ash box
060	0620.50.60	Entwässerung	Drain cook
061	0620.50.61	Kolbenstangenschutzrohr	Piston rod cover
062	40052.50.62	Fahrgestell	Chassis
063	3371.99.00	Glühbirne	Bulb
064	0620.50.64	Platine AC/DC	Pcb
065	0620.50.65	Schraube Aschekasten	Screw ash box
066	0620.50.66	Zahnrad 1	Gearwheel set 1
067	0620.50.67	Zahnrad 2	Gearwheel set 2
068	0620.50.68	Zahnrad 3	Gearwheel set 3
069	0620.50.69	Kreuzkopf rechts	Crosshead right
070	0620.50.70	Kreuzkopf links	Crosshead left
071	40052.50.71	Kreuzkopfgleitbahn rechts	Crosshead support right
072	40052.50.72	Kreuzkopfgleitbahn links	Crosshead support left
073	40052.50.73	Getriebeabdeckung	Gear box cover
074	0620.50.74	Schraube Getriebeabdeckung	Screw gear box cover
075	0600.99.43	Pick-up Pin	Pick up pin
076**	2225	Schleifer	Pick up shoe
077*	0620.50.77	Radschleifer	Wheel pick up
078*	40052.50.78	Halteplatte	Holder
079	0620.50.79	Senkkopfschraube	Screw
080	0620.50.80	6-Kant-Schraube	Screw
081	0620.50.81	Kuppelstange 1	Couple rod 1
082	0620.50.82	Kuppelstange 2	Couple rod 2
083	0620.50.83	Kuppelstange 3	Couple rod 3
084*	40052.50.84	Radsatz DC mit Hafreifennut	Wheel set DC with rubber tires
085	0620.50.85	Hafreifen	Rubber tire
086*	40052.50.86	Radsatz DC ohne Hafreifennut	Wheelset DC without rubber tires
087*	40052.50.87	Radsatz DC ohne Antrieb	Wheelset DC without gear wheel
088**	40053.50.88	Radsatz AC ohne Antrieb	Wheelset AC without gear wheel
089**	40053.50.89	Radsatz AC ohne Hafreifennut	Wheelset AC without rubber tires
090**	40053.50.90	Radsatz AC mit Hafreifennut	Wheel set AC with rubber tires
091	40052.50.91	Entwässerungsrohr hinten	Drain cook rear
092	0620.50.92	Motorabdeckung	Motor cover
094	0620.50.94	Stecker Lokseite	Pluck loco side
095	0620.50.95	Elektrisches Kuppelstück	Socket
096	0620.50.96	Stecker Tenderseite	Plug tender side
097	0620.50.97	Radlauf rechts	Wheel casing right
098	0620.50.98	Radlauf links	Wheel casing left
099	40052.50.99	Werkzeugkasten rechts	Tool box right

* Bauteil wird nur bei Gleichstrom-Ausführung verwendet.

** Bauteil wird nur bei Wechselstrom-Ausführung verwendet.





Ersatzteilliste BR 53 Spare Parts List BR 53

100	40052.50.100	Werkzeugkasten links	Tool box left
101	0620.50.101	Kohleeinsatz	Coal imitation
102	40052.50.102	Aufsetzbrett	Coal box top
103	0620.50.103	Notseilträger support	Emergency rope
104	0620.50.104	Griffstange Tender rechts	Handrail tender right
105	0620.50.105	Griffstange Tender links	Handrail tender left
106	0620.50.106	Werkzeugkasten hinten	Tool box rear
107	0620.50.107	Einfülldeckel	Water filler
108	40052.50.108	Tenderaufbau	Tender body
109	40052.50.109	Vorderteil Tender	Tender front part
110	0620.50.110	Griffring	Handrail
111	0620.50.111	Handbremshebel	Hand brake lever
112*	0530.99.34	Blindstecker	Blind plug
113	40052.50.113	Bremsbacken	Brake block unit
114	40052.50.114	Sandrohr	Sand pipe
115	40052.50.115	Radsatz Tender	Wheel set tender
116	40052.50.116	Zurüstteile	Add-on parts
		- Bremsschlauch Knorr 4x	- Air brake hose Knorr 4x
		- Bremsschlauch Westinghouse 4x	- Air brake hose Westinghouse 4x
		- Originalkupplung 2x	- Imitation coupling 2x
		- Schienenräumer 1x	- Chassis cover dummy 1x



* Bauteil wird nur bei Gleichstrom-Ausführung erwendet.

** Bauteil wird nur bei Wechselstrom-Ausführung verwendet.



Wichtiger Hinweis!

Bei der Bestellung von Ersatzteilen muss die Bestell-Nr. und die Benennung angegeben werden. Ist dies nicht der Fall, kann die Bestellung nicht bearbeitet werden.

Important notice!

When ordering spare parts you must always state the order number and give the description. If you do not do this, the order cannot be processed.

Bestellbeispiel:

Position (33), Motor kpl. = 0620.50.33 Motor kpl.

Order example:

Position (33), Motor cpl. = 0620.50.33 Motor cpl.



Brawa Artur Braun Modellspielwarenfabrik GmbH + Co.

Uferstraße 26-28 · D-73630 Remshalden

Telefon +49 (0)7151 - 97 93 50

Telefax +49 (0)7151 - 7 46 62

<http://www.brawa.de>

40052.50.117 / 03 08 - WAN

