

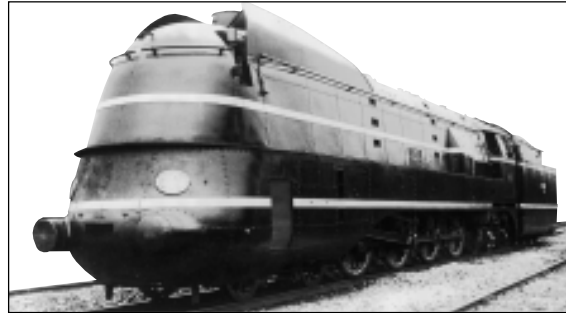

Betriebsanleitung Dampflokomotive mit Schleppender BR 06 H0



**Ausführung Gleichstrom
Ausführung Wechselstrom**



Die Deutsche Reichsbahn Gesellschaft schrieb 1934 den Bau einer vierfach gekuppelten Schnellzuglok aus. Den Auftrag für den Bau von zunächst zwei Lokomotiven der Baureihe 06 erhielt die Firma Krupp in Essen. Der Bau der Dampflokomotive BR 06 001 dauerte von 1934 bis 1939. Diese lange Bauzeit lässt sich nur damit erklären, dass schon bald nach der Auftragserteilung das Interesse der DR an dieser „Riesenlokomotive“ schwand. Als die Dampflokomotive BR 06 001 im März 1939 ausgeliefert wurde, war bereits die Realisierung der Baureihe 01.10 als neue Generation schwerer Schnellzugloks beschlossen worden. Die Baureihe 06 hatte Treibräder von 2000 mm Durchmesser und je ein vorderes und hinteres Drehgestell. Das Dreizylinder-Triebwerk sollte Laufruhe bis zu einer Höchstgeschwindigkeit von 140 km/h ermöglichen. Gekuppelt mit dem 5-achsigen Tender T38St hatte die BR 06 eine LüP von 26520 mm und war so die größte deutsche Schnellzuglok. Die Reibungslast betrug 80 t, die Dienstlast der Lok 141 t, das Gesamtgewicht von Lok und Tender 224 t. Sehr zufrieden war man mit dem Fahrwerk der Baureihe 06, mehrere zeitgenössische Berichte heben ausdrücklich den ruhigen Lauf der Maschine auch bei hohen Geschwindigkeiten hervor. Die hohe Zugkraft weckte ebenfalls Begeisterung. Weniger zufriedenstellend war dagegen der Betrieb mit dem Kessel, der mit 7,50 m Rohrlänge zum Problemkind geworden war. Das von der Reichsbahn verfochtene Prinzip des Langrohrkessels mit kleiner Feuerbüchseheizfläche war in eine Sackgasse geraten. Bis 1952 standen die Loks in Frankfurt und Hanau, dann wurden sie in Darmstadt und Braunschweig verschrottet.





Locomotive with trailing tender BR 06 H0

Operating Instructions

Direct current model

Alternating current model

In 1934, the Deutsche Reichsbahn Gesellschaft gave out an invitation to tender for the construction of an express train with four couplings. The initial construction order was for two locomotives from the 06 series and was awarded to Krupp in Essen. The construction of the steam locomotive BR 06 001 took from 1934 to 1939. This long construction time can only be explained by the fact that shortly after the order was given, DR's interest in the "giant locomotive" faded. When the locomotive was finally delivered in March 1939, the decision to realise the 01.10 series, a new generation of heavy express train locomotives, had been made. The 06 series had driving wheels with a diameter of 2000 mm and both a front and rear bogie. The three-cylinder valve gear and connecting rods was supposed to enable easy running up to a top speed of 140 km/h. When coupled to the 5-axle tender T38St, the BR 06 had a total length of 26 520 mm which made it the largest German express train. The frictional load was 80t, the locomotive's service weight was 141t, the total weight of the locomotive and tender was 224t. They were very pleased with the chassis of the 06 series, several reports of the time expressly complimented on the smooth running of the machine even at high speed. The high level of pulling power was also cause for enthusiasm! Less satisfactory however, was the tank which had become a problem with its 7.5 m long pipe. The principle which the Reichsbahn favoured, the long piped tank with small firebox heating surfaces, had come to a dead end. Until 1952 the locomotives stood in Frankfurt and Hanau and then they were scrapped in Darmstadt and Braunschweig.





Maßstabs- und originalgetreue Kleinmodelle für erwachsene Sammler.



Scale and true to original small-sized model for adult collectors.



Zum Betrieb des vorliegenden Produkts darf als Spannungsquelle nur ein nach VDE 0551/EN 60742 gefertigter Spielzeug-Transformator verwendet werden.

Only a toy transformer produced compliant with VDE 0551/EN 60742 may be used as a voltage source to operate this product.



Elektro- und Elektronikaltgeräte dürfen nicht in den Hausmüll gelangen. Sie müssen entsprechend der jeweils gültigen Länderrichtlinien fachgerecht entsorgt werden.



Electrical equipment may not reach to domestic waste. According to the current terms of the country reference the electrical equipment must professional disposed.





Inhaltsverzeichnis Contents

Benennung	Seite
Allgemeine Montage- und Sicherheitshinweise	5
Entnahme der Lok aus der Verpackung	6
Wichtige Arbeiten vor der Inbetriebnahme	6
Zusatzbauteile montieren	7
Wartungsarbeiten	
• 1. Ölen	8
• 2. Seuthe Raucheinsatz montieren	8
• 3. Umrüsten auf Digitalbetrieb	9
• 4. Lokomotivengehäuse demontieren	10
• 5. Tendergehäuse demontieren	10
• 6. Platine tauschen	10
• 7. Motor tauschen	10
• 8. Digitaldecoder tauschen	10
• 9. Haftreifen tauschen	10
• 10. Schleifer tauschen bei Wechselstromausführung	10
• 11. Glühbirnen tauschen	10
• 12. Wartungsarbeiten an Radsätze und Getriebe	10
Ersatzteilliste	
Gleichstrom- und Wechselstrom-Ausführung	14 – 18
Bestellbeispiel	18
Funktionstastenbelegung für Soundmodelle	19



Description	Page
General assembly and safety information	5
Removing the locomotive from the packaging	6
Important work before starting	6
Fitting additional parts	7
Maintenance works	
• 1. Lubricating	8
• 2. Mounting the Seuthe smoke insert	8
• 3. Conversion to digital operation	9
• 4. Dismantling Locomotive housing	12
• 5. Dismantling Tender housing	12
• 6. Exchanging the circuit board	12
• 7. Exchanging motor	12
• 8. Exchanging digital decoder	12
• 9. Exchanging traction tires	12
• 10. Exchanging pick-up on alternating current version	12
• 11. Exchanging bulbs	12
• 12. Maintenance work on wheel sets and gear	12
Spare parts list	
Direct current and alternating current	14 – 18
Order example	18
Function keys for soundmodels	19





Allgemeine Montage- und Sicherheitshinweise

- Diese Bedienungsanleitung beschreibt sämtliche Arbeitsvorgänge die zur Wartung und Instandhaltung notwendig sind. Bitte lesen Sie diese Bedienungsanleitung bevor Sie mit den Arbeiten beginnen.
- Bei unsachgemäßem Umgang mit elektrischen Bauteilen können diese zerstört werden. Für entsprechende Arbeiten (z.B. Platinenwechsel) können Sie sich an Ihren Fachhändler oder den Hersteller wenden.
- Bei den folgenden Wartungsarbeiten ist die jeweilige Demontage beschrieben, der Zusammenbau ist in umgekehrter Reihenfolge auszuführen.
- Die folgenden Wartungsarbeiten sind bei Gleich- und Wechselstrom-Ausführungen fast identisch. Im Ausnahmefall wird im entsprechenden Textabschnitt Bezug genommen.
- Empfohlene Betriebsarten in Abhängigkeit vom Schienenradius:

Schienenradius	Betrieb
300 mm	nicht Zulässig
360 mm	max. 50 % der Geschwindigkeit
420 mm	empfohlener Radius



General assembly and safety information



- These operating instructions describe all work steps necessary for maintenance and repair. Please read these operating instructions carefully before you start with your work.
- In the case of incorrect handling of electrical components, they may be destroyed. Please ask your specialist dealer to help with the necessary work (e.g. changing circuit boards).
- In the case of maintenance work, the disassembly is described below, to re-assemble the tractor reverse the work steps.
- Recommend operating modes in dependency of the rail radius:

Rail radius	Operation
300 mm	not allowed
360 mm	max. 50 % speed
420 mm	Recommend one radius





Arbeiten vor der Inbetriebnahme Work to be performed before starting up

Entnahme der Lok aus der Verpackung (Fig. 1)

Verpackung öffnen. Kunststoff-Schutzverpackung mit Lok entnehmen und auf einen Tisch oder ähnliches abstellen. Lasche (1) lösen, Deckel und Seitenteile der Schutzverpackung wegklappen, Lok entnehmen.

Removing the locomotive from the Packaging (Fig. 1)

Open package. Take out plastics protecting package with engine and put it down on a table or similar item. Loosen latch (1), fold away lid and side parts of protecting package, take out engine.

Fig. 1

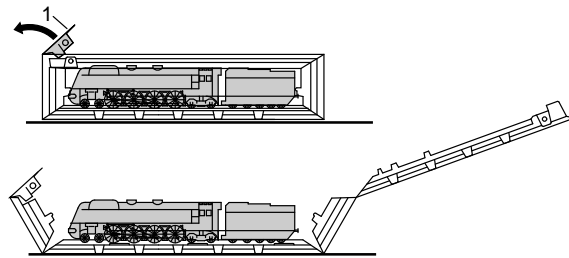

Wichtige Arbeiten vor der Inbetriebnahme (Fig. 2)

Lösen Sie die Schrauben (1) an der Unterseite der Lokomotive, um die Zylinderabdeckungen (2) und die Blenden (3) abzumontieren, da diese für den Fahrbetrieb nicht geeignet sind.

Important work before starting (Fig. 2)

Remove the screws (1) from the underside of the locomotive in order to dismantle the cylinder covers (2) and the panels (3), because they are not suitable for the driving mode.

Fig. 2

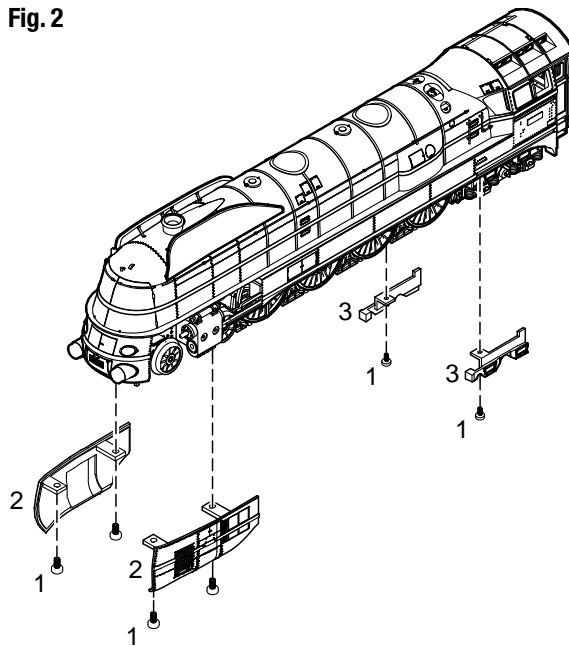



Zusatzbauteile montieren (Fig. 3)

In der Verpackung sind zusätzliche Bauteile lose beigelegt.

- 1 = 2 x Bügelkupplung
- 2 = Faltenbalg klein
- 3 = Faltenbalg groß
- 4 = 2 x Bügel für Faltenbalg klein
- 5 = 2 x Bügel für Faltenbalg groß
- 6 = 2 x Heizschlauch
- 7 = 4 x Bremsschlauch
- 8 = Lichtmaschine
- 9 = 2 x Originalkupplung
- 10 = 2 x Kolbenschutzrohr

Werden die Bauteile Pos. 9 und 10 für Vitrinenmodelle montiert, ist die Lok nicht mehr für den Fahrbetrieb geeignet.

Fitting additional parts (Fig. 3)

Accessory parts have been loosely enclosed in the packaging.

- 1 = 2 x Bow coupling
- 2 = Diaphragm open style
- 3 = Diaphragm close style
- 4 = 2 x Support for Diaphragm open style
- 5 = 2 x Support for Diaphragm close style
- 6 = 2 x Heating hose
- 7 = 4 x Brake hose
- 8 = Dynamo
- 9 = 2 x Original coupling
- 10 = 2 x Piston rod cover pipe

If the components from the add-on bag for display models are mounted, then the engine will no longer be suitable for operation.

Fig. 3

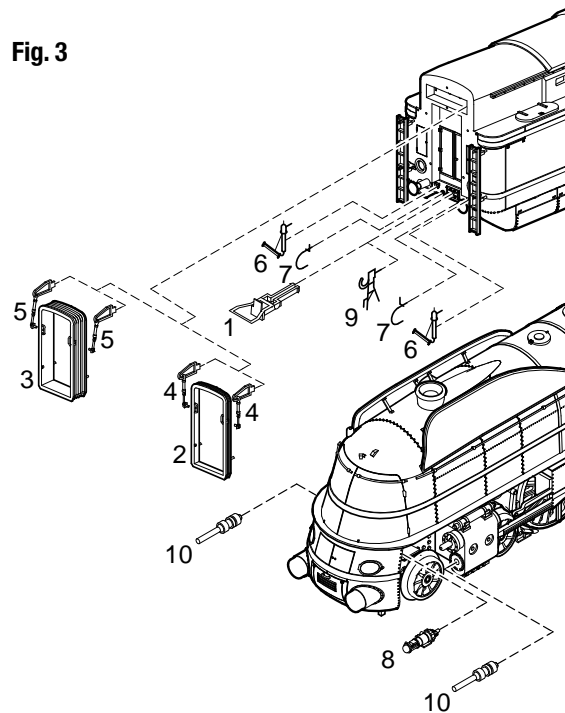



Wartungsarbeiten Maintenance works

1. Ölen (Fig. 4)

Der Motor und die Lagerstellen der Radsätze können an den gekennzeichneten Punkten sparsam mit Öl der Modellbaubranche geölt werden. Zum Ölen des Motors ist das Gehäuse abzunehmen, siehe Seite 10 Punkt 4.

1. Lubricating (Fig. 4)

The engine and the wheelset bearings may be sparingly lubricated at the marked places with oil used for model making purposes. In order to lubricate the engine, remove the housing, compare page 12, item 4.

Fig. 4

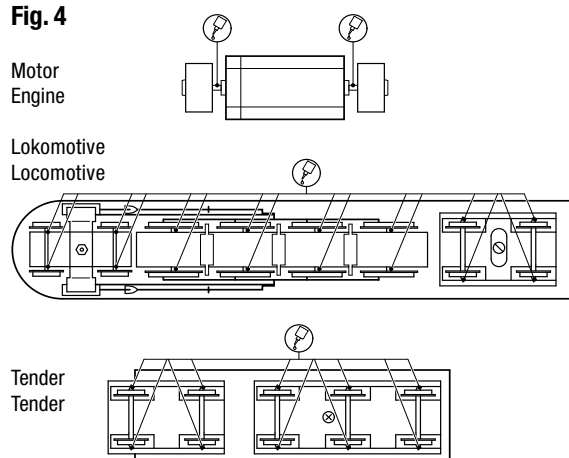

2. Seuthe Nr. 20 Raucheinsatz montieren (Fig. 5)

Gehäuse abnehmen, siehe Seite 10 Punkt 4.
Raucheinsatz (Pos. 1, Bestell-Nr. 9750.52.01) in Hülse (2) einsetzen und Gehäuse montieren.

2. Mounting the Seuthe No. 20 smoke insert (Fig. 5)

Remove housing, compare page 12, item 4.
Place the smoke insert (Pos. 1, Order no. 9750.52.01) in the sleeve (2) and mount the housing.

Fig. 5

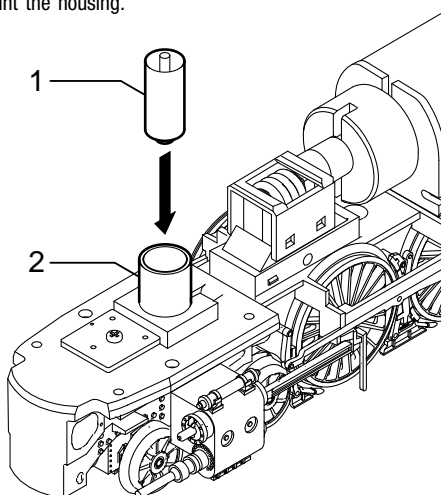



Umrüsten auf Digitalbetrieb

Gleichstrom Ausführung

Tendergehäuse abnehmen, Blindstecker (04) abziehen und Digital-Decoder (05) einstecken (siehe Seite 11).

Den richtigen Einbau des Digitaldecoders und dessen Einsteckrichtung entnehmen Sie der Einbauvorschrift des Decoderherstellers. Nach Einstecken des Digitaldecoders ist die Funktion des Lichtes zu prüfen. Wenn keine Lichtfunktion – Stecker um 180° drehen und einstecken.

Wechselstrom-Ausführung

Lokomotiven in Wechselstrom-Ausführung AC werden serienmäßig mit Premium-Digitaldecoder (05) ausgeliefert. Der Decoder erkennt die Betriebsart (analog/digital) selbstständig. Soll der Decoder umprogrammiert werden, liegt die Einbau- und Betriebsanleitung Premium-Digitaldecoder bei.

Der Decoder ist werkseitig auf Adresse 03 eingestellt.

Converting to digital operation

DC version

Remove Tenderhousing, pull off dummy connector (04) and insert digital decoder (13), (see page 13).

Please consult the installation instructions issued by the decoder manufacturer for correct installation of the digital decoder and its insert direction.

After inserting the digital decoder, check that the light functions. If the light does not work, turn the connector through 180°.

AC version

The premium digital decoder (05) is standard for the alternating current (AC) locomotives models. The decoder independently identifies the operation type (analog/digital). Please refer to the enclosed installation and operation instructions "Premium Digital Decoder" in the event that the decoder needs to be reprogrammed.

The decoder is set to address 03 in the factory.



Wartungsarbeiten

4. Lokomotivgehäuse demontieren (Fig. 6)

Schrauben (01) an der Gehäuseunterseite herausdrehen, Lokomotivgehäuse (02) vorsichtig nach oben abnehmen.

5. Tendergehäuse demontieren (Fig. 6)

Schrauben (01) an der Gehäuseunterseite herausdrehen, Tendergehäuse (03) vorsichtig nach oben abnehmen.

6. Platine tauschen (Fig. 6)

Tendergehäuse abnehmen, siehe Punkt 5.

Blindstecker (04) bei Gleichstrom-Ausführung DC oder Digitaldecoder (05) bei Wechselstrom-Ausführung AC abziehen. Befestigungsschraube (06) herausdrehen. Sämtliche Kabel, von der Platine (07), durch abziehen der Kabelschuhe (08), ablösen.

Bitte kennzeichnen Sie sich wo die einzelnen Kabel angebracht waren. Platine nach oben abnehmen.

7. Motor tauschen (Fig. 6)

Lokomotivgehäuse abnehmen, siehe Punkt 4.

Getriebeabdeckung (09) mit kleinem Schraubendreher ausclippen. Schnecke (10) und Kardanwelle (11) aus Halterung entfernen.

Motor mit Motorhalterung (12) mittels Schraubendreher am Grundträger ausclippen. Motor nach oben herausnehmen und Kabel (13) ablöten.

Achtung: Bei Ausbau des Motors auf Einbaulage achten – sonst falsche Fahrrichtung.

8. Digitaldecoder tauschen (Fig. 6)

Tendergehäuse abnehmen, siehe Punkt 5.

Digitaldecoder (05) abziehen und neuen einstecken.

9. Haftreifen tauschen (Fig. 6)

Lokomotivgehäuse abnehmen, siehe Punkt 4. Sechskantschrauben SW 2,5 (14) der Kuppelstange herausdrehen. Kuppelstange vorsichtig anheben und Haftreifen (15) wechseln.

10. Schleifer tauschen bei Wechselstromausführung (Fig. 6)

Befestigungsschraube (16) des Schleifers (17) herausdrehen, Kabel ablöten und Schleifer abnehmen.

11. Glühbirnen tauschen (Fig. 6)

Gehäuse abnehmen, siehe Punkte 4 und 5.

Schraube (18) an Kontaktplatine (19, 20) herausdrehen und Kontaktplatine lösen. Kabel der defekten Glühbirne (21) an Kontaktplatine ablöten. Glühbirne mit Lampenfassung aus Lampengehäuse herausziehen. Einbau in umgekehrter Reihenfolge.

12. Wartungsarbeiten an Radsätze und Getriebe (Fig. 6)

Bei Wartungsarbeiten an den Radsätzen (22), dem Kuppelgestänge (23) und dem Getriebe muss das gesamte Fahrgestell zerlegt werden. Wir bitten Sie bei der Demontage des Fahrgestells genau darauf zu achten, wo und wie jedes Einzelteil montiert war.

Die Einbaulage können Sie auch aus der Ersatzteilgrafik Seite 14 und 15 ersehen. Vor dem Zerlegen des Fahrgestells muss das Gehäuse demontiert werden (siehe Punkt 4 und 5). Für Beschädigungen, die durch unsachgemäße Arbeiten an den Bauteilen entstehen, kann die Firma BRAWA nicht haftbar gemacht werden.



BRAWA
LIEBE ZUM DETAIL

Fig. 6

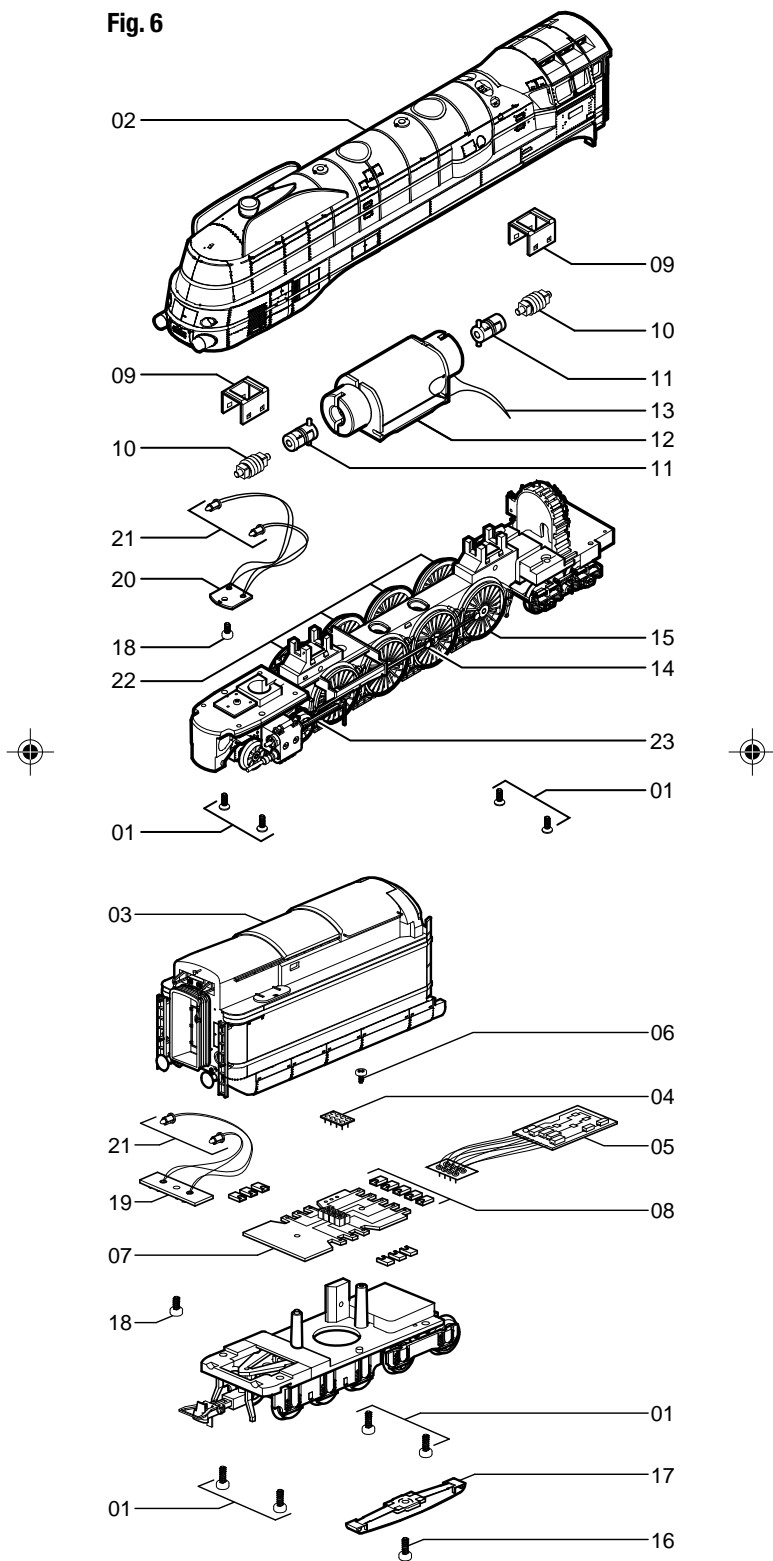



Maintenance works

4. Dismantling locomotive housing (Fig. 6)

Unscrew the screws (01) on the underside of housing, then remove locomotive housing (02) carefully upwards.

5. Dismantling tender housing (Fig. 6)

Unscrew the screws (01) on the underside of housing, then remove tender housing (03) carefully upwards.

6. Exchanging circuit board (Fig. 6)

Remove tender housing, see item 5.

Remove dummy plug (04) on direct-current type DC or digital decoder (05) on alternating current type AC.

Unscrew mounting screw (06). Release all cables from circuit board (07) by pulling off cable lug (08). Please make a note of where each cable is connected. Remove circuit board upwards.

7. Exchanging motor (Fig. 6)

Remove locomotive housing, see item 4.

Using a small screwdriver, unclip gear cover (09), then remove endless screw (10) and cardan shaft (11) from their holders. Unclip motor with motor holder (12) from basic holder, using a screwdriver. Remove motor upwards and unsold the cables (13).

Note: When removing the engine, please note the installation position, otherwise direction may be wrong.

8. Exchanging digital decoder (Fig. 6)

Remove tender housing, see item 5.

Remove digital decoder (05) and plug in a new one.

9. Exchanging traction tires (Fig. 6)

Remove locomotive housing, see item 4. Unscrew hexagon bolt SW 2,5 (14) from coupling rod. Lift coupling rod carefully and exchange traction tires (15).

10. Exchanging pick-up on alternating current version (Fig. 6)

Unscrew mounting screw (16) of pick-up (17), unsolder cables and take off pick-up.

11. Exchanging bulbs (Fig. 6)

Remove housing, see item 4 and 5.

Unscrew the screw (18) on contact circuit board (19, 20) and remove contact circuit board. Unsolder cable of the broken bulb (21) from the contact circuit board. Take off bulb from its holder. Installation in reverse order.

12. Maintenance work on wheel sets and gear (Fig. 6)

When maintaining the wheel sets (22), coupler (23) and gear, the whole bogie must be unscrewed. When dismantling the bogie, make precise notes about where and how each single part is installed. For the installation position please refer to the spare parts chart on page 14 and 15. Before dismantling the bogie the housing has to be dismantled (see item 4 and 5). The BRAWA company cannot be made liable for damage resulting from faulty maintenance work.





BRAWA
LIEBE ZUM DETAIL

Fig. 6

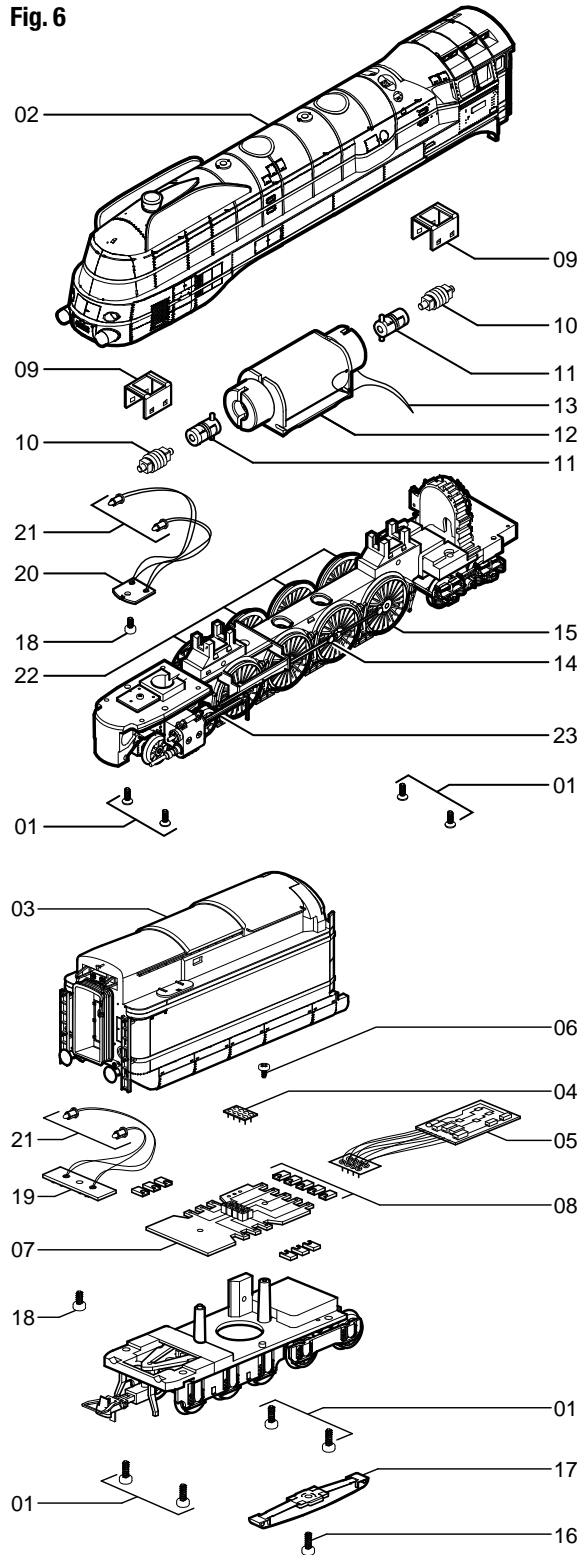

Ersatzteilliste
Spare Parts List

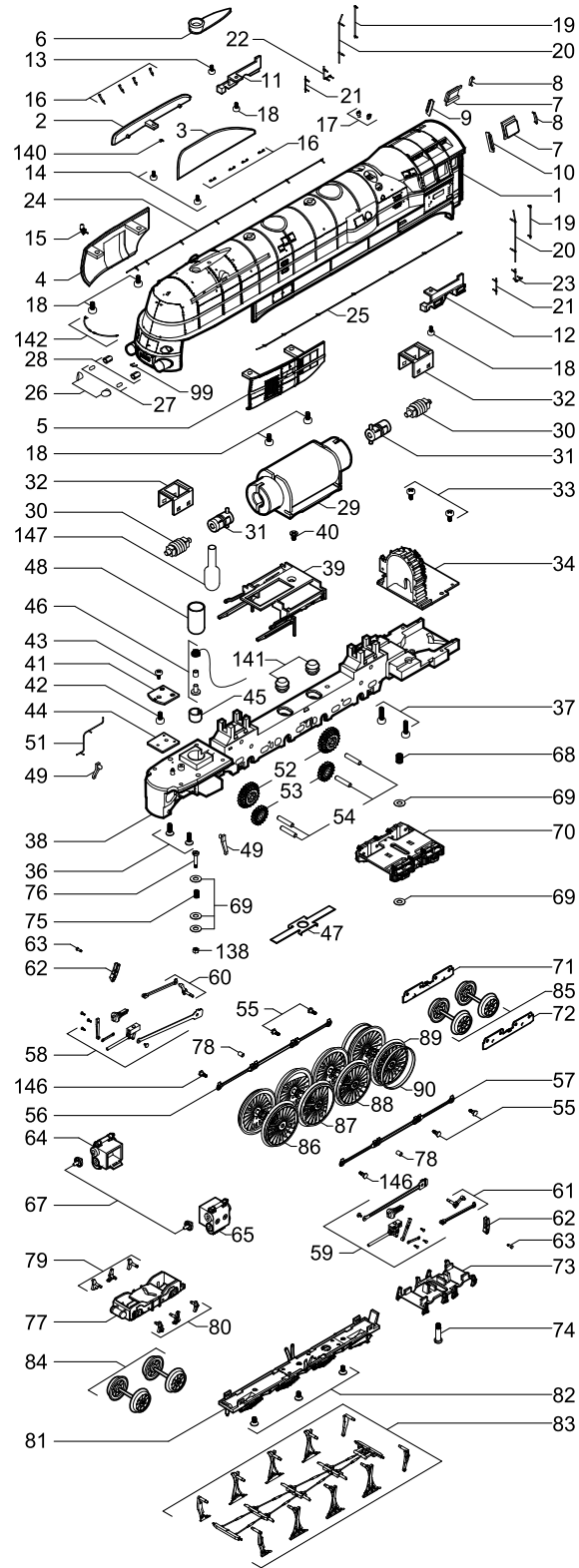



BRAWA
LIEBE ZUM DETAIL

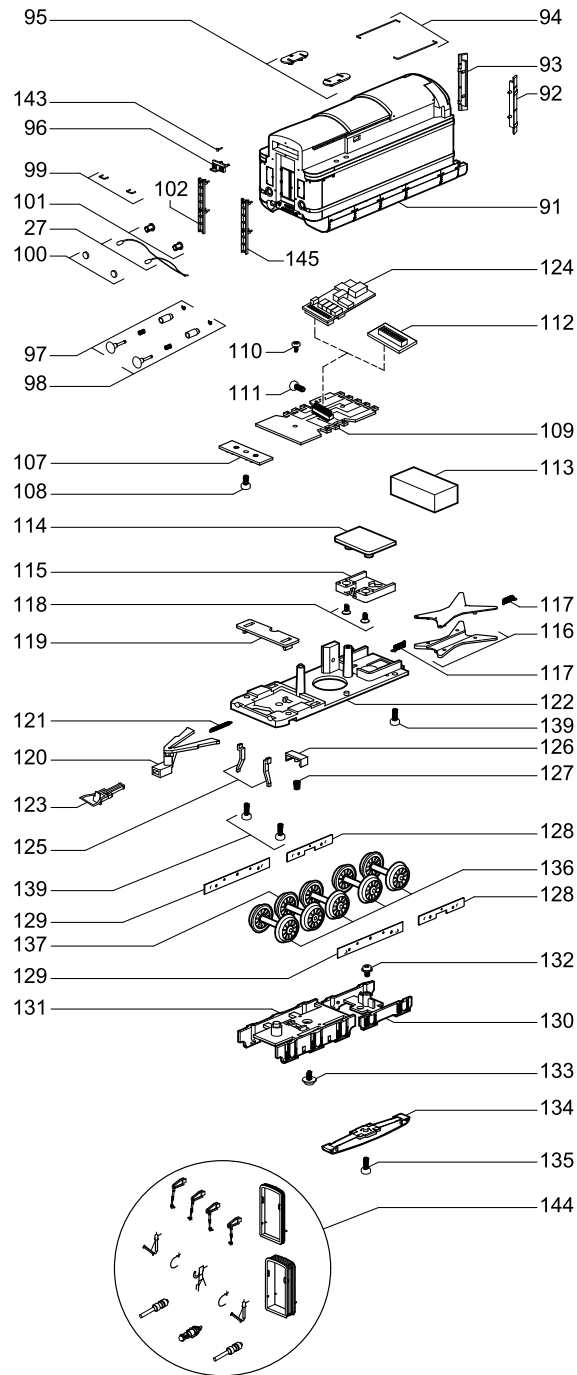

Ersatzteilliste Spare Parts List

Pos.	Bestell-Nr. Order no.	Benennung	Description
1	40212.50.01	Gehäuse kpl.	Body cpl.
2	0630.50.02	Windleitblech rechts	Spoiler right
3	0630.50.03	Windleitblech links	Spoiler left
4	0630.50.04	Seitenteil rechts	Sidepart right
5	0630.50.05	Seitenteil links	Sidepart left
6	0630.50.06	Schornstein	Chemney
7	0630.50.07	Seitenfenster	Cabinside windowglas
8	0630.50.08	Windabweiser	Windshield
9	0630.50.09	Frontscheibe rechts	Window front right
10	0630.50.10	Frontscheibe links	Window front left
11	0630.50.11	Blende rechts Fahrgestell	Cover right
12	0630.50.12	Blende links Fahrgestell	Cover left
13	0630.50.13	Schraube für Schornstein	Screw for chemney
14	0630.50.14	Schraube für Windleitblech	Screw for Spoiler
15	0630.50.15	Pfeife	Whistle
16	0630.50.16	Halter für Windleitblech	Holder for Spoiler
17	0630.50.17	Sicherheitsventil	Safety valve right
18	0630.50.18	Schraube für Seitenteil	Screw
19	0630.50.19	Griffstange	Handrail
20	0630.50.20	Griffstange lang	Handrail long
21	0630.50.21	Griffstange kurz	Handrail short
22	0630.50.22	Griffstange rechts	Handrail right Bended
23	0630.50.23	Griffstange links gebogen	Handrail left Bended
24	0630.50.24	Griffstange Kessel rechts	Handrail boiler right
25	0630.50.25	Griffstange Kessel links	Handrailboiler left
26	0630.50.26	Lampenglas links und rechts	Lamp glass
27	3268.99.00	Gühhampen	Bulbs
28	0630.50.27	Hülsen für Glühlampen	Cover for Bulb
29	0630.50.28	Motor kpl.	Motor cpl.
30	0630.50.29	Schnecke kpl.	Worm
31	0630.50.30	Kardan kpl.	Cardan cpl.
32	0630.50.31	Halterung für Schnecke	Worm cover
33	0630.50.32	Schraube Inneneinrichtung	Screw
34	0630.50.33	Inneneinrichtung	Interior
36	0630.50.35	Gehäuseschraube vorn	Screw
37	0630.50.36	Gehäuseschraube hinten	Screw
38	0630.50.37	Rahmen kpl.	Main frame
39	0630.50.38	Steuerungsträger kpl.	Control support
40	0630.50.39	Schraube für Steuerungs-	Screw
41	0630.50.40	Lampenplatine	PCB for bulbs
42	0630.50.41	Schraube für Platine	Screw
43	0630.50.42	Schraube für	Screw
44	0630.50.43	Kontaktplatine	PCB for Frontlight
45	0630.50.44	Hülse	Washer
46	0630.50.45	Kabel für Rauchgenerator	Contact pin
47	0630.50.46	Blattfeder	Axel spring
48	0630.50.47	Einsatz für Rauch	Electric muff
49	0630.50.48	Schienenräumer	Rear right Side track
51	0630.50.50	Leitung kpl.	Hose
52	0630.50.51	Zahnrad groß	Gear wheel big
53	0630.50.52	Zahnrad klein	Gear wheel small
54	0630.50.53	Achse	Axle
55	40204.50.54	Sechskantschraube	Screw for wheel
56	40212.50.55	Kuppelstange rechts	Couple rod right
57	40212.50.56	Kuppelstange links	Couple rod left
58	0630.50.57	Gestänge rechts	Rods right
59	0630.50.58	Gestänge links	Rods left
60	0630.50.59	Kurbelzapfen kpl. rechts	Rods right
61	0630.50.60	Kurbelzapfen kpl. links	Rods left
62	0630.50.61	Wipphebel	Expansion link
63	0630.50.62	Splint	Pin
64	0630.50.63	Zylinder rechts	Cylinder right
65	0630.50.64	Zylinder links	Cylinder left
67	0630.50.66	Abdeckung für Zylinder	Separate part for cylinder
68	0630.50.67	Druckfeder hinten	Spring for rear bogie
69	0630.50.68	Scheibe	Washer
70	0630.50.69	Drehgestell hinten	Rear bogie
71	0630.50.70	Stromabnahmeblech	Pick-up rear bogie right
72	0630.50.71	Stromabnahmeblech links	Pick-up rear bogie left DC
73	0630.50.72	Bremseinheit kpl. hinten	Rear bogie brake block



Pos.	Bestell-Nr. Order no.	Benennung	Description
74	0630.50.73	Distanzschraube hinten	Screw for rear bogie
75	0630.50.74	Druckfeder vorn	Spring for front bogie
76	0630.50.75	Distanzschraube vorn	Screw for front bogie
77	0630.50.76	Drehgestell kpl. vorn	Front bogie
78	0630.50.77	Distanzhülse	Washer
79	0630.50.78	Bremsbacken kpl. rechts	Brake right Front bogie
80	0630.50.79	Bremsbacken kpl. links	Brake left Front bogie
81	0630.50.80	Getriebeabdeckung kpl.	Frame basic plate
82	0630.50.81	Schraube Getriebeab-	Screw
83	0630.50.82	Bremsgestänge kpl.	Brake linkage
84	0630.50.83	Radsatz Vorlauf DC	Wheelset DC
	0631.50.83	Radsatz Vorlauf AC	Wheelset AC
85	0630.50.84	Radsatz Nachlauf DC	Wheelset DC
	0631.50.84	Radsatz Nachlauf AC	Wheelset AC
86	40212.50.85	1. Kuppelradsatz DC	1. Wheelset DC
	40213.50.85	1. Kuppelradsatz AC	1. Wheelset AC
87	40212.50.86	2. Kuppelradsatz DC	2. Wheelset DC
	40213.50.86	2. Kuppelradsatz AC	2. Wheelset AC
88	40212.50.87	3. Kuppelradsatz DC	3. Wheelset DC
	40213.50.87	3. Kuppelradsatz AC	3. Wheelset AC
89	40212.50.88	4. Kuppelradsatz DC	4. Wheelset DC
	40213.50.88	4. Kuppelradsatz AC	4. Wheelset AC
90	0630.50.89	Haftreifen	Traction tire
91	0630.50.90	Gehäuse Tender kpl.	Body Tender
92	0630.50.91	Blende Tender rechts	Sliding flap right
93	0630.50.92	Blende Tender links	Sliding flap left
94	0630.50.93	Griffstangen Tender	Handrail tender
95	0630.50.94	Deckel Tender	Cover for tender
96	0630.50.95	Lokschild (Tender)	Number plate
97	0630.50.96	Puffer gewölbt	Buffer round
98	0630.50.97	Puffer gerade	Buffer flat
99	0630.50.98	Griffstange klein	Handrail small
100	0630.50.99	Lampenglas	Lamp glass
101	0630.50.100	Hülse für Lampe Tender	Cover for bulb
102	0630.50.101	Leiter rechts	Ladder right
107	0630.50.106	Platine für Licht	PCB for bulb
108	0630.50.107	Schraube für Platine	Screw for pcb
109	0630.50.108	Platine	PCB
110	0630.50.109	Schraube	Screw
111	0630.50.110	Schraube für Transistor	Screw
112	40208.99.34	Blindstecker	Blind plug
113	0630.50.111	Gewicht Tender	Weight for tender
114	0630.50.112	Abdeckung Kinematik	Cover for coupler pocket
115	0630.50.113	Kinematik	Coupler pocket
116	0630.50.114	Deichsel kpl.	Connecting plate
117	0630.50.115	Feder für Deichsel	Spring
118	0630.50.116	Schraube für Kinematik	Screw
119	0630.50.117	Abdeckung für Kurz-	Cover connecting plate
120	0630.50.118	Normschacht	Coupler pocket
121	0630.50.119	Feder für Normschacht	Spring for coupler pocket
122	0630.50.120	Rahmen kpl. Tender	Main frame tender
123	9952.50.03	Bügelkupplung	Coupler
124	9750.50.80	Premium-Digitaldecoder	Premium digital decoder
	9750.50.82	Sounddecoder	Sounddecoder
125	0630.50.121	Schienenräumer	Front right side track
126	0630.50.122	Abdeckung	Cover
127	0630.50.123	Feder	Spring
128	0630.50.124	Stromabnehmer klein DC	Pick-up small DC
129	0630.50.125	Stromabnehmer groß DC	Pick-up large DC
130	0630.50.126	Drehgestell klein	Bogie tender small
131	0630.50.127	Drehgestell groß	Bogie tender large
132	0630.50.128	Lagerschraube	Screw
133	0630.50.129	Lagerschraube	Screw
134	2225	Schleifer AC	Pick-up shoe
135	0631.50.131	Schraube für Schleifer DC	Screw for pick-up shoe
136	0630.50.132	Tender-Radsatz DC	Wheelset Tender DC
	0631.50.132	Tender-Radsatz AC	Wheelset Tender AC
137	0630.50.133	Tender-Radsatz DC	Wheelset Tender DC
	0631.50.133	Tender-Radsatz AC	Wheelset Tender AC
138	0630.50.134	Mutter	Nut





Ersatzteilliste Spare Parts List

Pos.	Bestell-Nr. Order no.	Benennung	Description
139	0630.50.135	Schraube für Gehäuse	Screw
140	0630.50.136	Signalhalter	Signal holder
141	0630.50.137	Gummipuffer Motorhalter	Motor bearing
142	0630.50.138	Griffstangen gebogen	Handrail bended
143	0630.50.139	Signalhalter Tender	Signal holder Tender
144	0630.50.140	Zurüstbeutel	Add-on bag
145	0630.50.141	Leiter links	Ladder left
146	40204.50.142	Schraube kurz	Screw short
147	9750.52.01	Rauchgenerator	Smoke generator

Wichtiger Hinweis!

Bei der Bestellung von Ersatzteilen muss die Bestell-Nr. und die Benennung angegeben werden. Ist dies nicht der Fall, kann die Bestellung nicht bearbeitet werden.

Bestellbeispiel:

Position (15), Pfeife = 0630.50.15, Pfeife

Bestellung Digital-Sounddecoder

Bei der Bestellung des Digital-Sounddecoder geben Sie bitte zusätzlich zur Ersatzteil-Bestell-Nr. die Benennung und die Bestell-Nr. der entsprechenden Lok-Ausführung an. Nur so kann die richtige Funktionstastenbelegung für den Sound werksseitig vorprogrammiert werden.

Beispiel:

Position (124), Digital-Sounddecoder für Lok-Ausführung Dampflokomotive BR 06 = 9750.50.82, Digital-Sounddecoder für Lok-Ausführung Dampflokomotive BR 06.

Important notice!

When ordering spare parts you must always state the order number and give the description. If you do not do this, the order cannot be processed.

Order example:

Position (15), Whistle = 0630.50.15, Whistle

Order Digital sound decoder

With the order of the digital sound decoder you give please in addition to the spare part order no. the naming and the order no. of the suitable locomotive implementation in. Only so the right function key allocation can be preprogrammed for the sound.

Order example:

Position (124), Digital sound decoder for loco model steam locomotive BR 06 = 9750.50.82, Digital sound decoder for loco model steam locomotive BR 06.



Funktionstastenbelegung für Soundmodelle Function keys for Soundmodels

F0	Licht AN/AUS	Light ON/OFF
F1	Fahrgeräusch AN/AUS	Sound ON/OFF
F2	Pfeiffe	Whistle
F3	Kupplungsgeräusch	Coupler
F4	Rauch (Aux 1)	Smoke (Aux 1)
F5	Injektor	Injector
F6	Rangiergang	Shunting mode
F7	Kompressor	Airpump
F8	Kompressor langsam	Airpump slow
F9	Wasserpumpe	Water pump
F10	Kohle schaufeln	Coal shoveling
F11	Pfeiffe kurz	Whistle short
F12	Sicherheitsventil	Safety valve
F13	Rangierlicht	Shunting light





Brawa Modellspielwarenfabrik GmbH & Co.
Uferstraße 26-28 · D-73630 Remshalden
Hotline +49 (0) 7151 - 979 35 68
Telefax +49 (0) 7151 - 746 62
www.brawa.de

40212.50.150 / 05 10 - BRA

