



## Betriebsanleitung Dampflokk T 8 / BR 89.0



Nachdem die Eisenbahnbau- und Betriebsordnung ab dem 4. November 1904 auch auf Nebenbahnen eine Höchstgeschwindigkeit von 50 km/h zuließ, kam von mehreren Eisenbahndirektionen die Forderung nach einer C-gekuppelten Tenderlokk, die diese Geschwindigkeit auch fahren konnte.

1902 hat man eine solche Lok angesichts der in der Entwicklung befindlichen T 12 noch verworfen. Der geheime Baurat und Heißdampfverfechter Robert Garbe plante eine Universallokk, die gleichermaßen im Reise- und Güterzugdienst einsetzbar war. Mit der Ausarbeitung der Konstruktion beauftragte man Linke-Hofmann in Breslau, aus deren Werkhallen dann 1908 auch die ersten Exemplare der preußischen T 8 rollten. Zwar konnte die neue Lok leistungs- und verbrauchsmäßig überzeugen, beim Personal war sie aufgrund ihrer schlechten Laufeigenschaften äußerst unbeliebt.

Die großen Räder und der fehlende Masseausgleich ließen die Lok bei höheren Geschwindigkeiten stark zucken, was zu so passenden Spitznamen wie "Knochenschüttler" führte. Ein weiterer Fehlschlag war das viel zu hohe Gewicht, das ihren Einsatz auf Nebenbahnen faktisch ausschloss. Wegen ihres guten Beschleunigungsvermögens sollte die T 8 dafür Leistungen im Berliner Vorortverkehr erbringen. Da hier dauernd Geschwindigkeiten von 60 km/h gefahren wurden, ließen die Klagen der Personale nicht lange auf sich warten und auch Triebwerksschäden waren die Folge. Recht schnell wanderten die 100 gebauten Lokomotiven daher in den Rangierdienst ab, wo sie besonders in den Industrierevieren an Rhein und Ruhr sowie in Schlesien gefragt waren.

Die Deutsche Reichsbahn Gesellschaft führte im endgültigen Umzeichnungsplan von 1925 noch 78 Maschinen der preußischen T 8 als neue Baureihe 89.0. Das Einsatzgebiet der Maschinen hatte sich inzwischen stark verschoben und lag mehrheitlich außerhalb der Preußischen Provinzen. Hochburgen waren jetzt die Direktionen Dresden und Stuttgart, während nur noch wenige Loks der Direktionen Altona und Hannover vorrangig in den Hafencities Bremen und Hamburg Dienst taten. Die Dresdner Loks waren über ganz Sachsen verstreut, während man in Württemberg T 8 unter anderem in Friedrichshafen, Aulendorf und Freudenstadt antreffen konnte.

Die einsetzende Weltwirtschaftskrise und die zu Kriegsende zahlreich neu beschafften Maschinen ließen die BR 89.0 schnell entbehrlich werden. Einige Maschinen gelangten an Privat- und Werkbahnen, der Rest wurde ausgemustert und verschrottet. Infolge der Verstaatlichung von Mecklenburgischer Friedrich Wilhelm Eisenbahn und Lokalbahn AG, kehrten allerdings Ende der 30er-Jahre vier Lokomotiven als 89 1001 - 89 1004 in den Bestand der jetzt als DRB firmierenden Staatsbahn zurück.

Zwei Loks (89 1001 und 1002) wurden 1940 an die Hoesch Hüttenwerke als Werklokk 26 und 27 verkauft. 89 1003 verblieb in den westlichen Besatzungszonen und kam 1946 zur Westfälischen Landeseisenbahn als Lok 88. Die 89 1004 gelangte zur DR der DDR, wo sie noch bis 1966 Dienst tat. Sie blieb erhalten und kann heute in der Außenstelle des DB-Museums im ehemaligen Bw Halle P wieder im grünen Lack als "Berlin 7001" besichtigt werden.





## Operating instructions

### Steam locomotive T8 / BR 89.0

---

After the 'Eisenbahnbau- und Betriebsordnung' ('Act for the Construction and Operations of Railways') also permitted a maximum speed of 50 kph on branch lines from 4th November 1904, several railway divisions requested a C-coupled tender locomotive which was also capable of achieving this speed.

In 1902, such a locomotive had been rejected in view of the T 12, which was at the development stage. The chief engineer and advocate of saturated steam Robert Garbe planned a universal locomotive which could be used both as for passenger and for freight trains. Linke-Hofmann in Breslau was commissioned with the development of the design, from whose factory halls the first Prussian T 8 engines then came in 1908. The new locomotive was impressive in terms of power and consumption, but it was extremely unpopular with personnel due to its poor running properties.

The large wheels and the lack of mass compensation made the locomotive judder at high speeds, which led to corresponding nicknames such as "boneshaker". Another blunder was the much too high weight, which prevented its use on branch lines de facto.

Due to its good acceleration, however, the T 8 was to provide good service on suburban lines in Berlin. As speeds of 60 kph were continually reached here, the complaints of the personnel were not long in coming and this also resulted in engine damage. The 100 locomotives that had been built were very quickly moved to shunting duties, where they were very much in demand in the industrial regions of the Rhine and Ruhr and in Silesia. The Deutsche Reichsbahn Gesellschaft listed 78 engines of the Prussian T 8 as the new series 89.0 in the final reclassification plan of 1925. The operational area of the engines had in the meantime changed significantly and was now mainly outside the Prussian provinces. The strongholds were now the divisions of Dresden and Stuttgart, whereas only a few locomotives of the Altona and Hanover divisions were still in service in the ports of Bremen and Hamburg. The Dresden locomotives were spread all over Saxony, whereas T 8 engines could be seen in Württemberg in Friedrichshafen, Aulendorf and Freudenstadt.

The onset of the global economic crises and the numerous engines purchased at the end of the war soon made the BR 89.0 dispensable.

Some engines went to private and works railways, the rest were decommissioned and scrapped. As a result of the nationalisation of the Mecklenburgischer Friedrich Wilhelm Eisenbahn und Lokalbahn AG, however, four locomotives returned to the stock of the state railway now known as DRB at the end of the 1930s.

In 1940, two locomotives (89 1001 and 1002) were sold to the Hoesch smelting works as works locomotives 26 and 27. 89 1003 remained in the western occupation zones and in 1946 went to the Westfälische Landeseisenbahn as locomotive 88. The 89 1004 went to the DR of the GDR, where it was in service until 1966. It was kept and can be seen today in the branch of the DB museum in the former Halle P depot in green livery as "Berlin 7001".





## Inhaltsverzeichnis Contents



<b>Benennung</b>	<b>Seite</b>
Allgemeine Montage- und Sicherheitshinweise .....	4
Entnahme der Lok aus der Verpackung .....	5
Zusatzbauteile montieren .....	6
<b>Wartungsarbeiten</b>	
• 1. Ölen .....	7
• 2. Lokomotivengehäuse demontieren .....	8
• 3. Platine tauschen .....	8
• 4. Motor tauschen .....	8
• 5. Digitaldecoder tauschen .....	8
• 6. Schleifer tauschen bei Wechselstromausführung .....	9
• 7. Beleuchtungseinrichtung .....	9
• 8. Kupplungsnormschacht an Lokomotive tauschen .....	9
• 9. Raucheinsatz Seuthe Nr. 20 montieren .....	9
• 10. Wartungsarbeiten an Radsätze und Getriebe .....	10
• 11. Umrüsten auf Digitalbetrieb .....	10
<b>Ersatzteilliste</b>	
Gleichstrom- und Wechselstrom-Ausführung .....	12 – 19
Bestellbeispiel .....	20
<b>Description</b>	<b>Page</b>
General assembly and safety information .....	4
Removing the locomotive from the packaging .....	5
Fitting additional parts .....	6
<b>Maintenance works</b>	
• 1. Lubricating .....	7
• 2. Dismantling the locomotive housing .....	8
• 3. Exchanging the motherboard .....	8
• 4. Exchanging the motor .....	8
• 5. Exchanging the digital decoder .....	8
• 6. Exchanging the pick-up in the AC version .....	9
• 7. Light fittings .....	9
• 8. Exchanging the standard coupling shaft on the locomotive .....	9
• 9. Mounting smoke insert Seuthe No. 20 .....	9
• 10. Maintenance work on the wheel sets and gears .....	10
• 11. Converting to digital operation .....	10
<b>Spare parts list</b>	
Direct current and alternating current .....	12 – 19
Order example .....	20





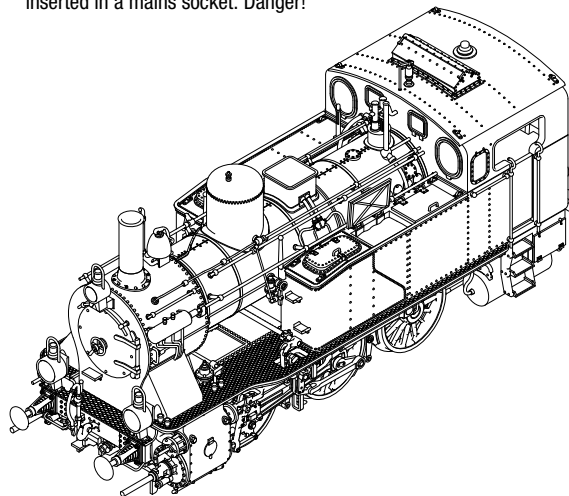
---

### Allgemeine Montage- und Sicherheitshinweise

- Diese Bedienungsanleitung beschreibt sämtliche Arbeitsvorgänge die zur Wartung und Instandhaltung notwendig sind. Bitte lesen Sie diese Bedienungsanleitung bevor Sie mit den Arbeiten beginnen.
- Bei unsachgemäßem Umgang mit elektrischen Bauteilen können diese zerstört werden. Für entsprechende Arbeiten (z.B. Platinenwechsel) können Sie sich an Ihren Fachhändler oder den Hersteller wenden.
- Bei den folgenden Wartungsarbeiten ist die jeweilige Demontage beschrieben, der Zusammenbau ist in umgekehrter Reihenfolge auszuführen.
- Die folgenden Wartungsarbeiten sind bei Gleich- und Wechselstrom-Ausführungen fast identisch. Im Ausnahmefall wird im entsprechenden Textabschnitt Bezug genommen.
- Jegliche Kabel oder Verbindungsdrähte die in diesem Produkt verbaut sind dürfen nicht in eine Netzsteckdose eingeführt werden. Lebensgefahr!

### General assembly and safety information

- These operating instructions describe all work steps necessary for maintenance and repair. Please read these operating instructions carefully before you start with your work.
- In the case of incorrect handling of electrical components, they may be destroyed. Please ask your specialist dealer to help with the necessary work (e.g. changing circuit boards).
- In the case of maintenance work, the disassembly is described below, to re-assemble the tractor reverse the work steps.
- The maintenance work described below is virtually identical for direct current and alternating current models. If there are any differences these will be pointed out specifically.
- All cables and connection wires installed in this product may not be inserted in a mains socket. Danger!





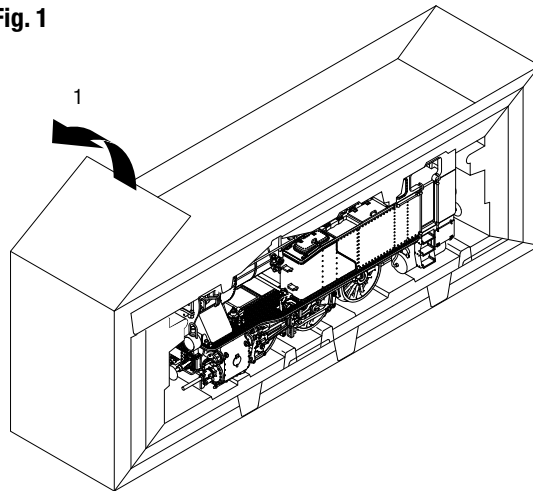
### Entnahme der Lok aus der Verpackung (Fig. 1)

Verpackung öffnen. Kunststoff-Schutzverpackung mit Lok entnehmen und auf einen Tisch oder ähnliches abstellen. Lasche (1) lösen, Deckel und Seitenteile der Schutzverpackung wegklappen, Lok entnehmen.

### Removing the locomotive from the packaging (Fig. 1)

Open package. Take out plastics protecting package with engine and put it down on a table or similar item. Loosen latch (1), fold away lid and side parts of protecting package, take out engine.

Fig. 1





## Arbeiten vor der Inbetriebnahme Work to be performed before starting up

### Zusatzbauteile montieren (Fig. 2)

In der Verpackung sind zusätzliche Bauteile lose beigelegt.

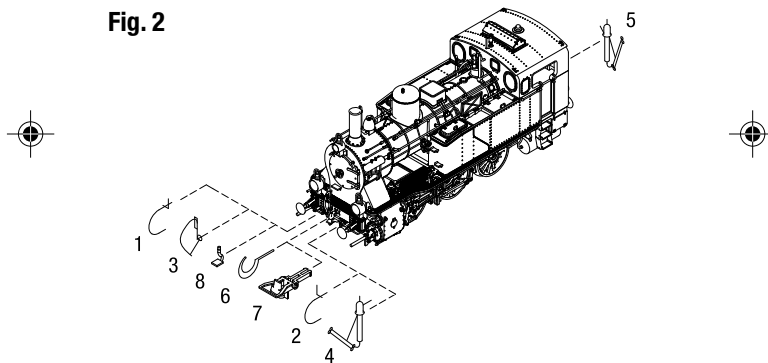
- 1 = 2 x Knorr Bremschlauch, rechts
- 2 = 2 x Knorr Bremschlauch, links
- 3 = 2 x Westinghouse Bremse
- 4 = 1 x Heizschlauch, links
- 5 = 1 x Heizschlauch, rechts
- 6 = 2 x Kupplungshaken
- 7 = 2 x Bügelkupplung
- 8 = 1 x Aufstieg vorne

### Fitting additional parts (Fig. 2)

Accessory parts have been loosely enclosed in the packaging.

- 1 = 2 x Knorr brake hose, right
- 2 = 2 x Knorr brake hose, left
- 3 = 2 x Westinghouse brake
- 4 = 1 x Heating hose, left
- 5 = 1 x Heating hose, right
- 6 = 2 x Original coupling
- 7 = 2 x Bow coupling
- 8 = 1 x Step front

Fig. 2





## Wartungsarbeiten Maintenance works



### 1. Ölen (Fig. 3)

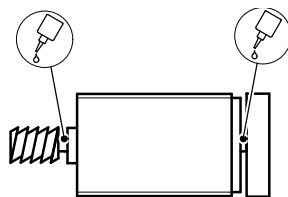
Der Motor und die Lagerstellen der Radsätze können an den gekennzeichneten Punkten sparsam mit Öl der Modellbaubranche geölt werden. Zum Ölen des Motors ist das Gehäuse abzunehmen, siehe Seite 8 Punkt 2.

### 1. Lubricating (Fig. 3)

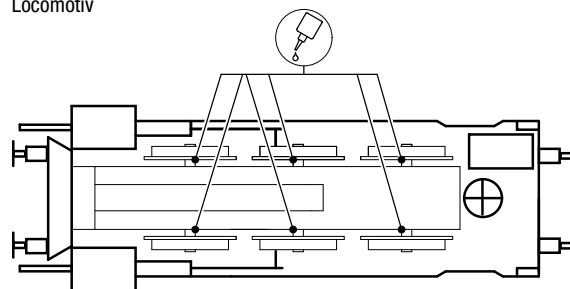
The engine and the wheelset bearings may be sparingly lubricated at the marked places with oil used for model making purposes. In order to lubricate the engine, remove the housing, compare page 8, item 2.

Fig. 3

Motor  
Engine



Lokomotive  
Locomotiv





## Wartungsarbeiten Maintenance works

### 2. Lokomotivgehäuse demontieren (Fig. 4)

Rauchkammertür (08) nach vorne abziehen. Abdeckung Werkzeugkasten (09) abnehmen. Schrauben (01) an der Gehäusesseite herausdrehen und Lokomotivgehäuse (02) vorsichtig nach oben abnehmen.

### 2. Dismantling the locomotive casing (Fig. 4)

Pull out the smoke box door (08). Remove the tool box cover (09). Unscrew the screws (01) on the side of the casing and lift up the locomotive housing (02) carefully.

### 3. Platine tauschen (Fig. 4)

Lokomotivgehäuse abnehmen, siehe Punkt 2.  
Blindstecker (229) bei Gleichstrom-Ausführung DC oder Digitaldecoder (121) bei Wechselstrom-Ausführung AC abziehen. Befestigungsschrauben (118) herausdrehen.  
Bitte kennzeichnen Sie sich wo die einzelnen Kabel befestigt waren.  
Platine (119) nach oben abnehmen.

### 3. Exchanging the motherboard (Fig. 4)

Remove the locomotive housing, see point 2.  
Remove blind socket (229) for direct current model DC or digital decoder (121) for alternating current version. Unscrew attachment screws (118).  
Please mark where the individual cables were fixed.  
Lift out motherboard (119).

### 4. Motor tauschen (Fig. 4)

Lokomotivgehäuse abnehmen, siehe Punkt 2.  
Bremsgestänge (174) abnehmen. Schrauben (145) der Bodenplatte (198) herausdrehen und Bodenplatte abnehmen. Schraube (115, an Fahrgestell) herausdrehen und Getriebegehäuse (108, 181) mit Motor (90) nach oben herausnehmen. Kabel am Motor ablöten. Schrauben (115) am linken Getriebegehäuse (181) herausdrehen. Zahnrad (112) und Motor (90) aus rechtem Getriebegehäuse (108) herausnehmen.

**Achtung: Bei Ausbau des Motors auf Einbaulage achten – sonst falsche Fahrtrichtung.**

### 4. Exchanging the motor (Fig. 4)

Remove locomotive housing, see point 2.  
Remove brake linkage (174). Unscrew the screw (145) of the base plate (198) and remove base plate. Unscrew the screw (115, chassis) and lift up the gear box (108, 181) with motor (90). Unsolder the cable to the motor. Unscrew the screw (115) at the left gear box (181). Take the gear (112) and motor (90) out off the right gear box (108).

**Warning: Please note the installation position of the motor when removing, otherwise wrong direction of motion.**

### 5. Digitaldecoder tauschen (Fig. 4)

Lokomotivgehäuse abnehmen, siehe Punkt 2.  
Digitaldecoder (121) abziehen und neuen einstecken.

### 5. Exchanging the digital decoder (Fig. 4)

Remove the locomotive housing, see point 2.  
Pull out digital decoder (121) and insert new unit.





## **6. Schleifer tauschen bei Wechselstromausführung**

### **(Fig. 4)**

Befestigungsschraube (230) des Schleifers (229) herausdrehen und Schleifer abnehmen.

## **6. Exchanging the pick-up in the AC version**

### **(Fig. 4)**

Unscrew the attachment screws (230) of the pick-up shoe support (229) and remove the pick-up shoe support.

## **7. Beleuchtungseinrichtung (Fig. 4)**

Diese Lokomotive ist mit wartungsfreien Leuchtdioden ausgestattet. Bei einem eventuellen Defekt der Leuchtdioden wenden Sie sich bitte an Ihren Fachhändler oder den Hersteller.

## **7. Light fittings (Fig. 4)**

This locomotive is fitted with maintenance-free light-emitting diodes. If a defect occurs in the light-emitting diodes, please contact your specialist dealer or the manufacturer.

## **8. Kupplungsnormschacht an Lokomotive tauschen**

### **(Fig. 4)**

Bremsgestänge (174) abnehmen. Schrauben (145) der Bodenplatte (198) herausdrehen und Bodenplatte abnehmen.

Feder (86, 182) aushängen. Kupplungsnormschacht (144) abnehmen und Bügelkupplung ausklipsen.

## **8. Exchanging the standard coupling shaft on the locomotive (Fig. 4)**

Remove brake linkage (174). Unscrew the screw (145) of the base plate (198) and remove base plate.

Put up the spring (86, 182). Remove the standard coupling shaft (144) and unclip the bow coupling.

## **9. Raucheinsatz Seuthe Nr. 20 montieren (Fig. 4)**

Lokomotivengehäuse abnehmen, siehe Punkt 2.

Raucheinsatz (Pos. 80, Bestell-Nr. 9750.52.01) in Isolierbuchse (130) einsetzen und an die vorhandenen Kabel anlöten. Gehäuse montieren.

## **9. Mounting smoke insert Seuthe No. 20 (Fig. 4)**

Remove the locomotive housing, see point 2.

Insert the smoke unit (item 80, Order No. 9750.52.01) in the isolating bush (130) and solder it at the existent cable. Fit housing.



## Wartungsarbeiten Maintenance works

### 10. Wartungsarbeiten an Radsätze und Getriebe

(Fig. 4)

Bei Wartungsarbeiten an den Radsätzen, dem Kuppelgestänge und dem Getriebe muss das gesamte Fahrgestell zerlegt werden. Wir bitten Sie bei der Demontage des Fahrgestells genau darauf zu achten, wo und wie jedes Einzelteil montiert war.

Die Einbaulage können Sie auch aus der Ersatzteilgrafik Seite 14 bis 17 ersehen. Für Beschädigungen, die durch unsachgemäße Arbeiten an den Bauteilen entstehen, kann die Firma BRAWA nicht haftbar gemacht werden.

### 10. Maintenance work on the wheel sets and gears

(Fig. 4)

When performing maintenance work on the wheel sets, the coupling rods and the gears, the whole chassis must be dismantled. We would remind you to note exactly where and how each part was assembled before dismantling the chassis. The installation position can be seen in the spare parts chart on pages 14 to 17. BRAWA is not liable for damage which occurs due to improper work on construction parts.

### 11. Umrüsten auf Digitalbetrieb

#### Gleichstrom-Ausführung

Lokomotivengehäuse (02) abnehmen, Blindstecker (229) abziehen und Digital-Decoder (121) einstecken.

**Den richtigen Einbau des Digitaldecoders und dessen Einsteckrichtung entnehmen Sie der Einbauvorschrift des Decoderherstellers.**

#### Wechselstrom-Ausführung

Lokomotiven in Wechselstrom-Ausführung AC werden serienmäßig mit Premium-Digitaldecoder (121) ausgeliefert. Der Decoder erkennt die Betriebsart (analog/digital) selbstständig. Soll der Decoder umprogrammiert werden, liegt die Einbau- und Betriebsanleitung Premium-Digitaldecoder bei.

Der Decoder ist werkseitig auf Adresse 03 eingestellt.

### 11. Converting to digital operation

#### DC version

Remove locomotive housing (02), pull off dummy connector (229) and insert digital decoder (121).

**Please consult the installation instructions issued by the decoder manufacturer for correct installation of the digital decoder and its insert direction.**

#### AC version

The premium digital decoder (229) is standard for the alternating current (AC) locomotives models. The decoder independently identifies the operation type (analog/digital). Please refer to the enclosed installation and operation instructions "Premium Digital Decoder" in the event that the decoder needs to be reprogrammed.

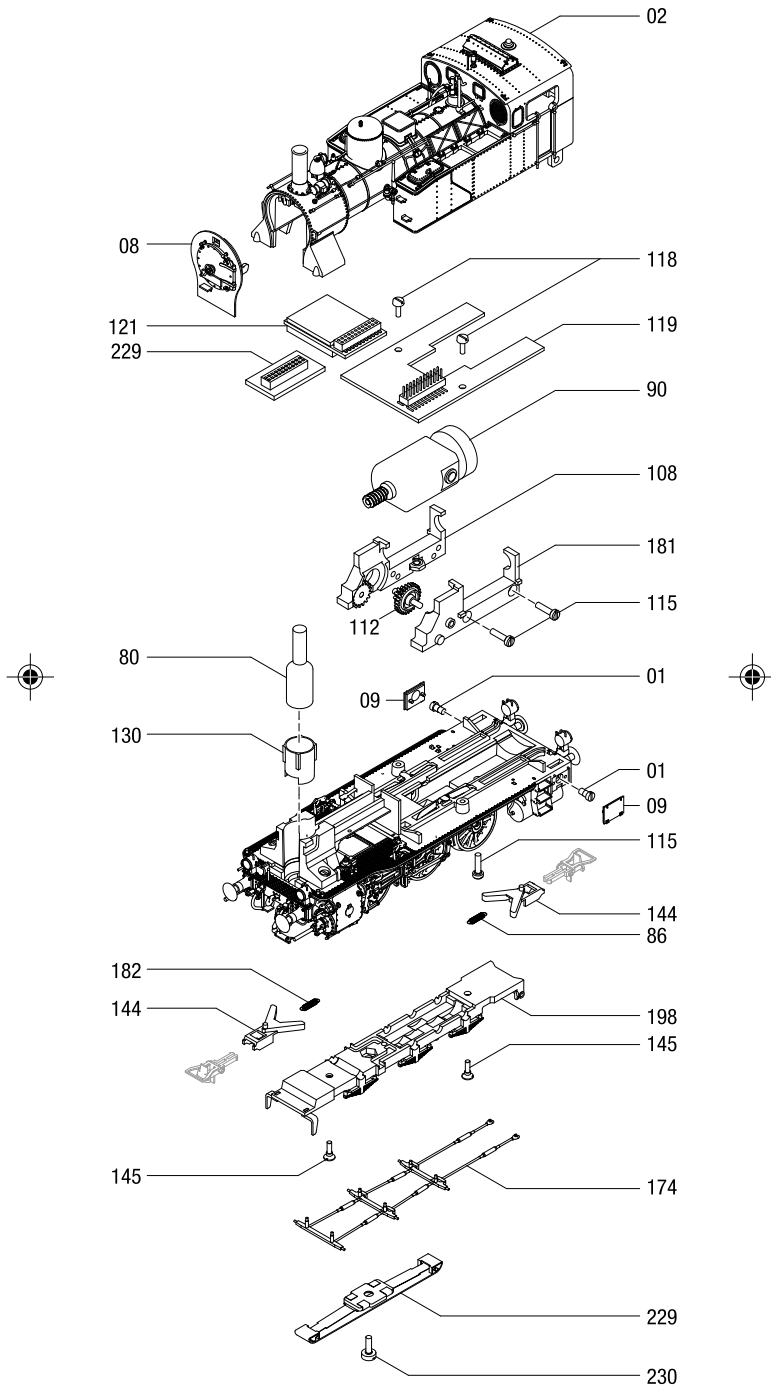
The decoder is set to address 03 in the factory.



# Wartungsarbeiten Maintenance works

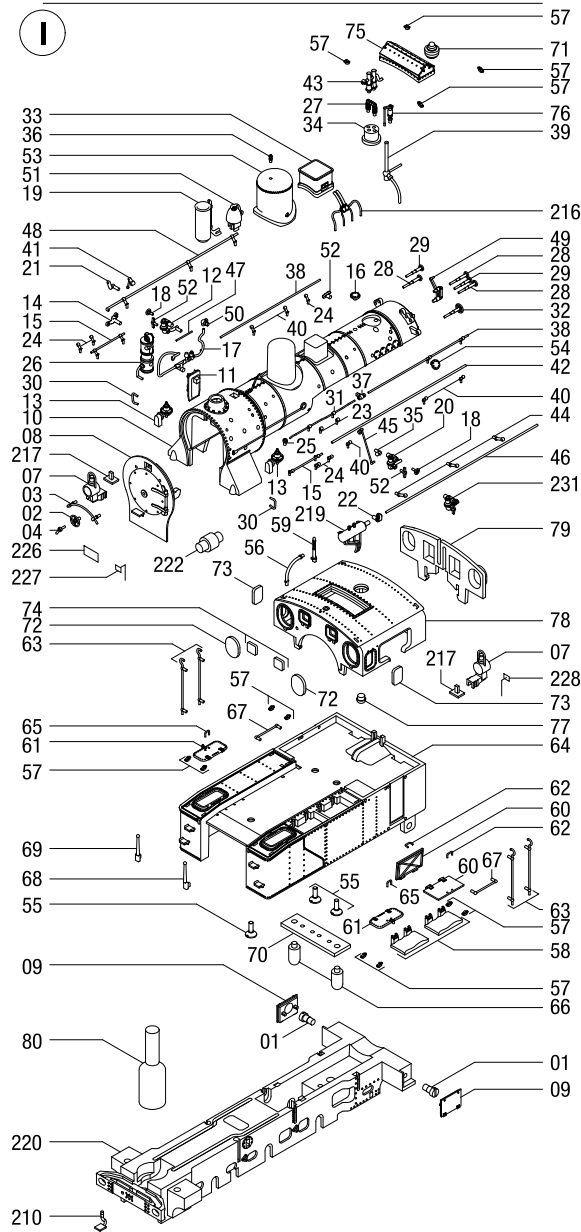
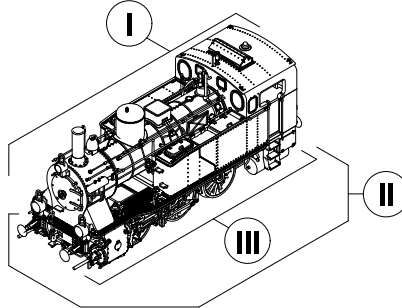


Fig. 4



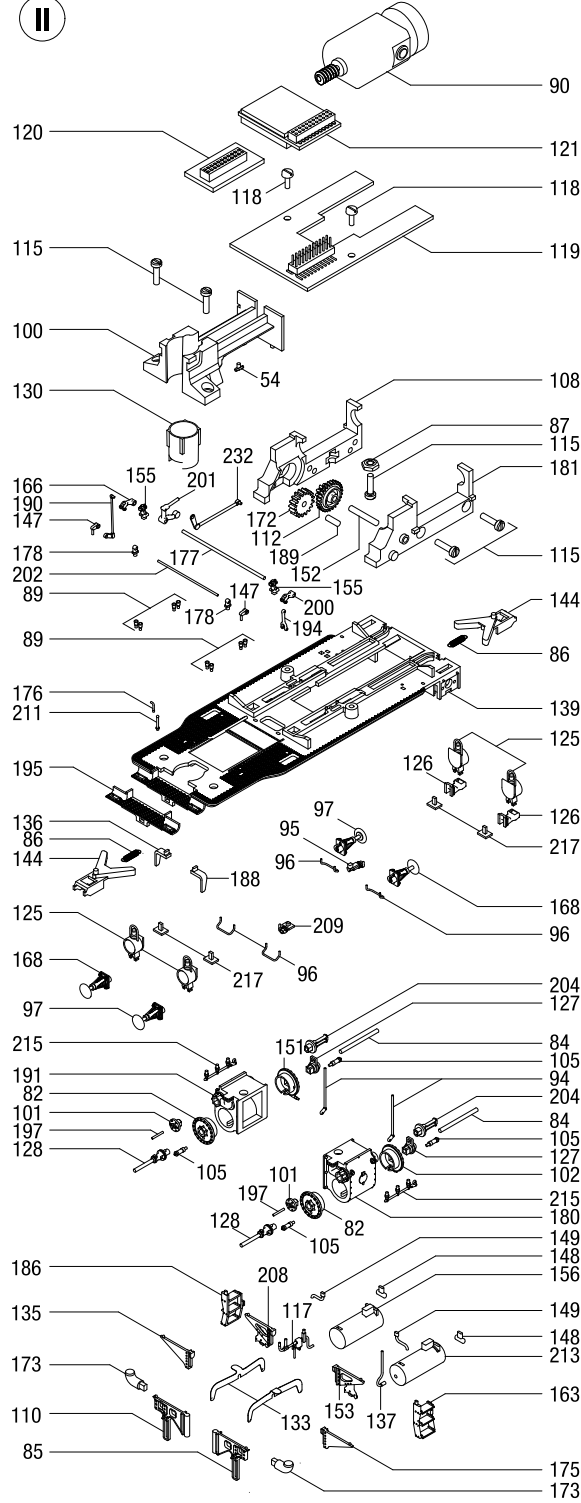


**Ersatzteilliste**  
**Spare parts list**



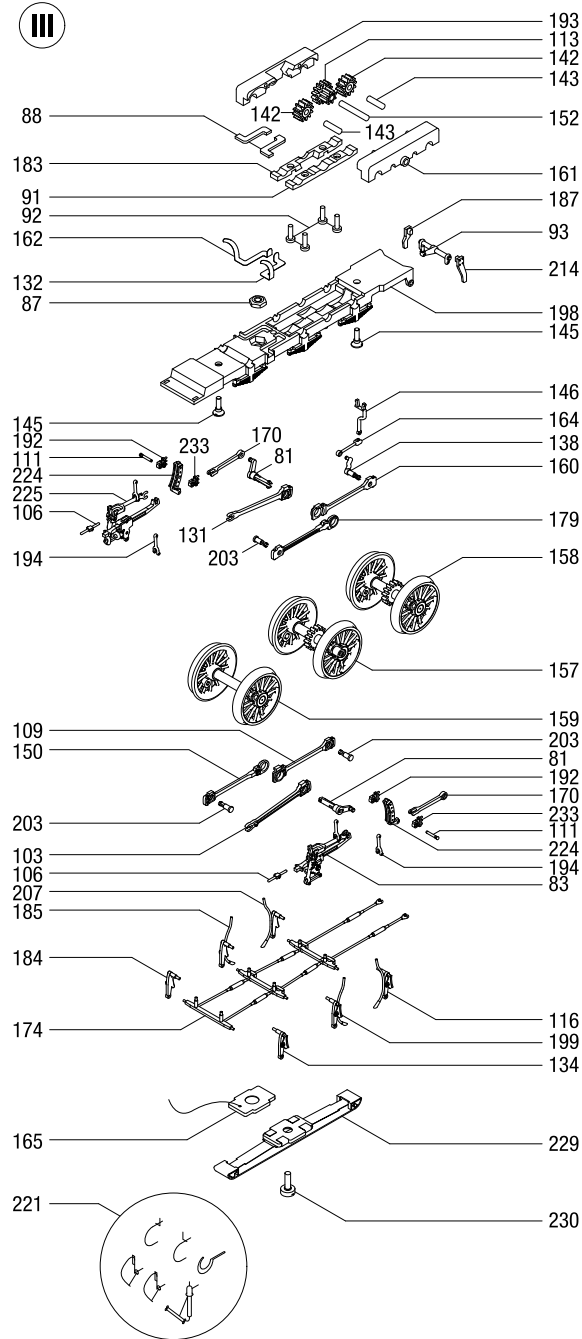


II





## Ersatzteilliste Spare parts list





Pos.	Bestell-Nr. Order no.	Benennung	Description
1	40500.50.01	Ansatzschraube	Shoulder screw
2	40500.50.02	Handrad	Hand wheel
3	40500.50.03	Griffstange	Handrail
		Rauchkammer für 40500	smoke box for 40500
	40504.50.03	Griffstange	Handrail
		Rauchkammer für 40504	smoke box for 40504
4	40500.50.04	Handrad Konter	Handwheel konter
7	40500.50.05	Lampe kpl. oben	Lamp cpl. top
8	40500.50.06	Rauchkammertür für 40500	Smoke box door for 40500
	40502.50.06	Rauchkammertür für 40502	Smoke box door for 40502
	40504.50.06	Rauchkammertür für 40504	Smoke box door for 40504
	40506.50.06	Rauchkammertür für 40506	Smoke box door for 40506
9	40500.50.07	Werkzeugkasten	Touling box
	40504.50.07	Werkzeugkasten für 40504	Touling box for 40504
10	40500.50.08	Kesseloberteil für 40500	Boiler top part for 40500
	40502.50.08	Kesseloberteil für 40502	Boiler top part for 40502
	40504.50.08	Kesseloberteil für 40504	Boiler top part for 40504
	40506.50.08	Kesseloberteil für 40506	Boiler top part for 40506
11	40500.50.09	Luftpumpenträger	Holder for air pump
12	40500.50.10	Kesselspeiseventil rechts	Boiler valve right
13	40500.50.11	Luftsaugventil	Air valve
14	40500.50.12	Hebel-Zylinderentwässerung	Crank cylinder drain
15	40500.50.13	Griffstange	Handrail
16	40500.50.14	Waschluke	Boiler wash out plug
	40504.50.14	Waschluke für 40504	Boiler wash out plug for 40504
17	40500.50.15	Luftpumpe Dampfleitung	Air pump steam cable
18	40500.50.16	Handrad	Hand wheel
19	40500.50.17	Schornstein	Chimney
20	40500.50.18	Kesselspeiseventil links	Boiler feed valve left
21	40500.50.19	Glockenventil	Bell valve
22	40500.50.20	Überhitzerwelle	Heating axle
23	40500.50.21	Leitungshalter	Holder for cable
24	40500.50.22	Griffstangenhalter	Holder for handrail
25	40500.50.23	Flansch	Adapter
26	40500.50.24	Luftpumpe	Air pump
27	40500.50.25	Sicherheitsventil	Safety valve
28	40500.50.26	Handrad	Hand wheel
29	40500.50.27	Handrad klein lang	Hand wheel small long
30	40500.50.28	Griff	Handle
31	40500.50.29	Leitung	Pipe
32	40500.50.30	Handrad groß	Hand wheel big
33	40500.50.31	Sandkasten für 40500	Sand box für 40500
	40504.50.31	Sandkasten für 40504	Sand box for 40504
	40506.50.31	Sandkasten für 40506	Sand box for 40506
34	40500.50.32	Sockel Sicherheitsventil	Socket Safety valve
	40504.50.32	Sockel Sicherheitsventil für 40504	Socket Safety valve for 40504
35	40500.50.33	Ventil	Valve
36	40500.50.34	Domventil	Dome valve
37	40500.50.35	Dampfentnahme links	Steam tapping left
38	40500.50.36	Pumpenzug	Bowden cable
39	40500.50.37	Schalldämpfer	Exhaust box
40	40500.50.38	Drehzughalter	Holder for bowden cable
41	40500.50.39	Drehzughebel rechts	Crank for bowden cable right
42	40500.50.40	Drehzug links	Bowden cable left
43	40500.50.41	Sicherheitsventil	Safety valve
44	40500.50.42	Zughalterautomat	Holder for bowden cable
45	40500.50.43	Drehzughebel links	Crank for bowden cable left
46	40500.50.44	Automatenzug	Bowden cable
47	40500.50.45	Luftpumpenzug	Bowden cable for air pump
48	40500.50.46	Entwässerungszug	Bowden cable for drain
49	40500.50.47	Regler	Controller
50	40500.50.48	Dampfentnahme rechts	Steam tapping right
51	40500.50.49	Läutewerk	Signal bell
52	40500.50.50	Löschgriff	Erasing handle
53	40500.50.51	Dampfdom für 40500	Steam dome für 40500
	40504.50.51	Dampfdom für 40504	Steam dome for 40504
	40506.50.51	Dampfdom für 40506	Steam dome for 40506
54	40500.50.14	Waschluke	Boiler wash out plug
	40504.50.14	Waschluke für 40504	Boiler wash out plug for 40504





## Ersatzteilliste Spare Parts List

Pos.	Bestell-Nr. Order no.	Benennung	Description
55	40500.50.53	Schraube	Screw
56	40500.50.54	Speiseleitung	Feed pipe
57	40500.50.98	Haken	Hook
	40504.50.98	Haken für 40504	Hook for 40504
58	40500.50.55	Kohleeinsatz	Coal insert
59	40500.50.56	Wasserstandanzeiger	Water gauge
60	40500.50.57	Deckel für Kohlekasten	Cover for coal box
	40504.50.57	Deckel für Kohlekasten für 40504	Cover for coal box for 40504
61	40500.50.58	Wassereinlass	Water inlet
	40504.50.58	Wassereinlass für 40504	Water inlet for 40504
62	40500.50.59	Griff Kohlekasten	Handle coal box
63	40500.50.60	Handgriff	Handrail
64	40500.50.61	Wasserkasten für 40500	Water tank for 40500
	40502.50.61	Wasserkasten für 40502	Water tank for 40502
	40504.50.61	Wasserkasten für 40504	Water tank for 40504
	40506.50.61	Wasserkasten für 40506	Water tank for 40506
65	40500.50.62	Griff Wassereinlass	Handle water inlet
66	40500.50.63	Federkontakt	Contact spring
67	40500.50.64	Griffstange	Handrail
68	40500.50.65	Griffstange	Handrail
		Wasserkasten links	water tank left
69	40500.50.66	Griffstange	Handrail
		Wasserkasten rechts	water tank right
70	40500.50.67	Leiterplatte	PCB
71	40500.50.68	Deckel für Führerstandsbeleuchtung	Cover for cabin light
72	40500.50.69	Stirnfenster 1	Front window 1
	40504.50.209	Stirnfenster 2 links für 40504	Front window 2 left for 40504
73	40500.50.70	Seitenfenster	Side window
74	40500.50.71	Stirnfenster 2	Front window 2
75	40500.50.72	Lüfteraufsatz	Ventilator
76	40500.50.73	Pfeife	Pipe
77	40500.50.74	Lampe Führerstand	Lamp for cabin
78	40500.50.75	Führerhaus für 40500	Cabin for 40500
	40504.50.75	Führerhaus für 40504	Cabin for 40504
	40506.50.75	Führerhaus für 40506	Cabin for 40506
79	40500.50.76	Fenster hinten	Window rear side
80	9750.52.01	Raucherzeuger Nr. 20	Smoke generator no. 20
81	40500.50.77	Gegenkurbel	Eccentric crane
82	40500.50.78	Zylinderdeckel vorne rechts	Cover cylinder front right
83	40500.50.79	Steuergestänge links kpl.	Control linkage left cpl.
	40504.50.79	Steuergestänge links kpl. für 40504	Control linkage left cpl. for 40504
84	40500.50.80	Zylinderstange	Cylinder rod
85	40500.50.81	Gleitbahnträger links	Slide way bearing left
	40504.50.81	Gleitbahnträger links 40504	Slide way bearing left 40504
86	40500.50.82	Zugfeder	Spring
87	40500.50.83	Sechskantmutter	Hex nut
88	40500.50.84	Radschleiferabdeckung	Cover for pic up
	40504.50.84	Radschleiferabdeckung für 40504	Cover for pic up for 40504
89	40500.50.85	Ölbehälter	Oil reservoir
	40504.50.85	Ölbehälter für 40504	Oil reservoir for 40504
90	40500.50.86	Motor kpl.	Motor cpl.
91	40500.50.87	Wippenverschluß	Cover
92	40500.50.88	Schraube	Screw
93	40500.50.89	Bremswelle	Brake axle
	40504.50.89	Bremswelle für 40504	Brake axle for 40504
94	40500.50.90	Entwässerungshebel	Drains crank
	40504.50.90	Entwässerungshebel für 40504	Drains crank for 40504
95	40500.50.91	Heizkupplungsanschluß	Adapter for heating hose
	40504.50.91	Heizkupplungsanschluß für 40504	Adapter for heating hose for 40504
96	40500.50.92	Rangiergriff	Buffer handle
	40504.50.92	Rangiergriff für 40504	Buffer handle for 40504
97	40500.50.93	Puffer flach für 40502	Buffer flat for 40500
	40502.50.93	Puffer flach für 40502	Buffer flat for 40502
	40504.50.93	Puffer flach für 40504	Buffer flat for 40504
	40506.50.93	Puffer flach für 40506	Buffer flat for 40506







Pos.	Bestell-Nr. Order no.	Benennung	Description
100	40500.50.94	Kesselunterteil	Boiler base part
	40504.50.94	Kesselunterteil für 40504	Boiler base part for 40504
101	40500.50.95	Schieberkastendeckel	Steam chest cover
102	40500.50.96	Zylinderdeckel hinten links	Cylinder cover rear left
103	40500.50.97	Treibstange links	Connecting rod left
	40504.50.97	Treibstange links für 40504	Connecting rod left for 40504
105	40500.50.99	Sicherheitsventil	Safety valve
106	40500.50.100	Schieberkreuzkopf	Piston valve crosshead
108	40500.50.102	Getriebegehäuse rechts	Gear box right
109	40500.50.103	Kuppelstange hinten links	Coupling rod rear left
110	40500.50.104	Gleitbahnträger rechts	Slide way bearing right
	40504.50.104	Gleitbahnträger rechts für 40504	Slide way bearing right for 40504
111	40500.50.105	Schwingenachse	Linkage axle
	40504.50.105	Schwingenachse für 40504	Linkage axle for 40504
112	40500.50.106	Zahnrad 1	Gear 1
113	40500.50.107	Zahnrad 2	Gear 2
115	40500.50.109	Schraube	Screw
116	40500.50.110	Bremshebel hinten links	Brake block rear left
	40504.50.110	Bremshebel hinten links für 40504	Brake block rear left for 40504
117	40500.50.111	Tropfbecher	Drain cup
	40504.50.111	Tropfbecher für 40504	Drain cup for 40504
118	40500.50.112	Schraube	Screw
119	40500.50.113	Hauptplatine	Main PCB
120	40500.50.140	Brückenstecker	Blind plug
121	9750.50.80	Decoder	Decoder
125	40500.50.114	Gaslampe	Gas lamp
	40502.50.114	Gaslampe für 40502	Gas lamp for 40502
126	40500.50.115	Lampenhalter	Holder for lamp
	40504.50.115	Lampenhalter für 40504	Holder for lamp for 40504
127	40500.50.116	Stopfbuchse	Compression gland
128	40500.50.117	Kolbenstangenschutz	Cock bar
130	40500.50.118	Isolierbuchse	Isolating bush
131	40500.50.119	Treibstange rechts	Connecting rod right
	40504.50.119	Treibstange rechts für 40504	Connecting rod right for 40504
132	40500.50.120	Radschleifer vorne links	Pic up front left
133	40500.50.121	Radschleifer	Pic up shoe
134	40500.50.122	Bremshebel vorne links	Brake block front left
	40504.50.122	Bremshebel vorne links für 40504	Brake block front left for 40504
135	40500.50.123	Umlaufstütze rechts	Walk way bearing right
	40504.50.123	Umlaufstütze rechts 40504	Walk way bearing right 40504
136	40500.50.124	Schienenräumer vorne rechts	Track cleaner front right
	40504.50.124	Schienenräumer vorne rechts für 40504	Track cleaner front right for 40504
137	40500.50.125	Rohr hinten links	Tube rear left
	40504.50.125	Rohr hinten links für 40504	Tube rear left for 40504
138	40500.50.126	Ölerkurbel	Oil crank
139	40500.50.127	Umlauf	Walk way
	40504.50.127	Umlauf für 40504	Walk way for 40504
142	40500.50.128	Zahnrad 3	Gear 3
143	40500.50.129	Lagerachse	Bearing shaft
144	40500.50.130	Normschacht	Coupler pocket
	40504.50.130	Normschacht für 40504	Coupler pocket for 40504
145	40500.50.131	Schraube	Screw
146	40500.50.132	Ölerstange	Oil rod
	40504.50.132	Ölerstange für 40504	Oil rod for 40504
147	40500.50.133	Wellenhebel	Corrugation rod
	40504.50.133	Wellenhebel für 40504	Corrugation rod for 40504
148	40500.50.134	Gassteckdose	Gas socket
	40504.50.134	Gassteckdose für 40504	Gas socket for 40504
149	40500.50.135	Schlabberrohr	Hose
	40504.50.135	Schlabberrohr für 40504	Hose for 40504
150	40500.50.136	Kuppelstange vorne links	Coupling rod front left
	40504.50.136	Kuppelstange vorne links für 40504	Coupling rod front left for 40504
151	40500.50.137	Zylinderdeckel hinten rechts	Cylinder cover rear right
152	40500.50.138	Lagerachse	Bearing shaft



## Ersatzteilliste Spare Parts List

Pos.	Bestell-Nr. Order no.	Benennung	Description
153	40500.50.139	Umlaufstütze links	Walk way bearing left
	40504.50.139	Umlaufstütze links für 40504	Walk way bearing left for 40504
155	40500.50.141	Steuerwellenlager	Control shaft bearing
	40504.50.141	Steuerwellenlager für 40504	Control shaft bearing for 40504
156	40500.50.142	Luftkessel rechts	Air tank right
	40504.50.142	Luftkessel rechts für 40504	Air tank right for 40504
157	40500.50.206	Radsatz DC	Wheelset DC
	40501.50.206	Radsatz AC für 40501	Wheelset AC for 40501
	40504.50.206	Radsatz DC für 40504	Wheelset DC for 40504
	40505.50.206	Radsatz AC für 40505	Wheelset AC for 40505
158	40500.50.143	Radsatz DC für 40500	Wheelset DC for 40500
	40501.50.143	Radsatz AC für 40501	Wheelset AC for 40501
	40504.50.143	Radsatz DC für 40504	Wheelset DC for 40504
	40505.50.143	Radsatz AC für 40505	Wheelset AC for 40505
159	40500.50.208	Radsatz DC für 40500	Wheelset DC for 40500
	40501.50.208	Radsatz AC für 40501	Wheelset AC for 40501
	40504.50.208	Radsatz DC für 40504	Wheelset DC for 40504
	40505.50.208	Radsatz AC für 40505	Wheelset AC for 40505
160	40500.50.144	Kuppelstange hinten rechts	Coupling rod rear right
161	40500.50.145	Getriebewippe	Gear box rocker
162	40500.50.146	Radschleifer vorne rechts	Pic up shoe front right
163	40500.50.147	Aufstieg Führerhaus links	Step drivers cabin left
	40504.50.147	Aufstieg Führerhaus links für 40504	Step drivers cabin left for 40504
164	40500.50.148	Ölerstange	Oil rod
	40504.50.148	Ölerstange für 40504	Oil rod for 40504
165	40501.50.149	Stromabnehmer	Pick up
166	40500.50.150	Aufwerfhebel rechts	Accumulate crank right
168	40500.50.151	Puffer gewölbt für 40500	Buffer round for 40500
	40502.50.151	Puffer gewölbt für 40502	Buffer round for 40502
	40504.50.151	Puffer gewölbt für 40504	Buffer round for 40504
	40506.50.151	Puffer gewölbt für 40506	Buffer round for 40506
170	40500.50.152	Schwingenstange	Linkage rod
172	40500.50.153	Zahnrad	Gear
173	40500.50.154	Verbindungsrohr	Connecting tube
	40504.50.154	Verbindungsrohr für 40504	Connecting tube for 40504
174	40500.50.155	Bremsgestänge	Brake linkage
	40504.50.155	Bremsgestänge für 40504	Brake linkage for 40504
175	40500.50.156	Umlaufstütze links	Walk way bearing left
	40504.50.156	Umlaufstütze links für 40504	Walk way bearing left for 40504
176	40500.50.157	Bremsrohrende	Brake tube end
	40504.50.157	Bremsrohrende für 40504	Brake tube end for 40504
177	40500.50.158	Steuerwelle	Control shaft
178	40500.50.159	Lagerbock Zylinder	Bearing case cylinder
179	40500.50.160	Kuppelstange vorne rechts	Coupling rod front right
180	40500.50.161	Zylinder links	Cylinder left
	40504.50.161	Zylinder links für 40504	Cylinder left for 40504
181	40500.50.162	Getriebegehäuse links	Gear box left
183	40500.50.164	Wippenverschluß	Rocker catch
184	40500.50.165	Bremshebel vorne rechts	Brake block front right
	40504.50.165	Bremshebel vorne rechts für 40504	Brake block front right for 40504
185	40500.50.166	Bremshebel mitte rechts	Brake block middle right
	40504.50.166	Bremshebel mitte rechts für 40504	Brake block middle right for 40504
186	40500.50.167	Aufstieg Führerhaus rechts	Step drivers cabin right
	40504.50.167	Aufstieg Führerhaus rechts für 40504	Step drivers cabin right for 40504
187	40500.50.168	Schienenräumer hinten links	Track cleaner rear left
	40504.50.168	Schienenräumer hinten links für 40504	Track cleaner rear left for 40504
188	40500.50.169	Schienenräumer vorne links	Track cleaner front left
	40504.50.169	Schienenräumer vorne links für 40504	Track cleaner front left for 40504
189	40500.50.170	Lagerachse	Bearing shaft
190	40500.50.171	Entwässerungszug	Bowden cable for drain



Pos.	Bestell-Nr. Order no.	Benennung	Description
191	40500.50.172	Zylinder rechts	Cylinder right
	40504.50.172	Zylinder rechts für 40504	Cylinder right for 40504
192	40500.50.173	Schwingenlager links	Linkage bearing left
	40504.50.173	Schwingenlager links für 40504	Linkage bearing left for 40504
193	40500.50.174	Getriebewippe	Gear rocker
194	40500.50.200	Hängeeisen	Hanger
195	40500.50.175	Abdeckung Pufferbohle	Cover buffer bole
	40504.50.175	Abdeckung Pufferbohle für 40504	Cover buffer bole for 40504
197	40500.50.176	Schieberstange vorne	Piston rod front
198	40500.50.177	Bodenplatte	Base plate
	40504.50.177	Bodenplatte für 40504	Base plate for 40504
199	40500.50.178	Bremshebel mitte links	Brake block middle left
	40504.50.178	Bremshebel mitte links für 40504	Brake block middle left for 40504
200	40500.50.179	Aufwurfhebel links	Accumulate crank left
	40504.50.179	Aufwurfhebel links für 40504	Accumulate crank left for 40504
201	40500.50.180	Steuerstangenhebel	Contol linkage
202	40500.50.181	Welle Entwässerung	Axle drain
203	40500.50.182	Kurbelbolzen	Crank bolt
204	40500.50.183	Schieberkastendeckel	Piston box cover
207	40500.50.184	Bremshebel hinten rechts	Brake block rear right
	40504.50.184	Bremshebel hinten rechts für 40504	Brake block rear right for 40504
208	40500.50.185	Umlaufstütze rechts	Walk way bearing right
	40504.50.185	Umlaufstütze rechts für 40504	Walk way bearing for 40504
209	40500.50.186	Heizungsanschluß	Heating adapter
	40504.50.186	Heizungsanschluß für 40504	Heating adapter for 40504
210	40500.50.187	Aufstieg vorne	Step front
	40504.50.187	Aufstieg vorne für 40504	Step front for 40504
211	40500.50.188	Handgriff	Hand rail
213	40500.50.190	Luftkessel links	Air tank left
	40504.50.190	Luftkessel links für 40504	Air tank left for 40504
214	40500.50.191	Schienenräumer hinten rechts	Track cleaner rear right
	40504.50.191	Schienenräumer hinten rechts für 40504	Track cleaner rear right for 40504
215	40500.50.192	Zylinderentwässerung	Cylinder drain
216	40500.50.193	Sandfallrohr	Sand pipe
217	40500.50.194	LED für Lampe	LED for Lampe
219	40500.50.196	Überhitzerautomat	Super heater automat
220	40500.50.197	Fahrgestell für 40500	Chassis for 40500
	40502.50.197	Fahrgestell für 40502	Chassis for 40502
	40504.50.197	Fahrgestell für 40504	Chassis for 40504
	40506.50.197	Fahrgestell für 40506	Chassis for 40506
221	40500.50.198	Zurüstbeutel	Add on part
	40504.50.198	Zurüstbeutel für 40504	Add on part for 40504
222	40504.50.199	Lichtmaschine	Generator
224	40500.50.201	Schwinge	Linkage
225	40500.50.202	Steuergestänge rechts kpl.	Control linkage right cpl.
	40504.50.202	Steuergestänge rechts kpl. für 40504	Control linkage right cpl. for 40504
226	40504.50.203	Nummernschild	Number plate
227	40504.50.204	Schlußscheibenhalter vorne	Signal support front
228	40504.50.205	Schlußscheibenhalter hinten	Signal support rear
229	2225	Wechselstromschleifer	AC pic up shoe
230	40500.50.207	Schraube	Screw
231	40504.50.210	Kesselspeiseventil links	Boiler feed valve left
232	40504.50.211	Entwässerungszug für Zylinder 1	De-watering bowden cable for cylinder 1
233	40500.50.212	Schwingenlager rechts	Linkage bearing right
	40504.50.212	Schwingenlager rechts für 40504	Linkage bearing right for 40504





#### Wichtiger Hinweis!

Bei der Bestellung von Ersatzteilen muss die Bestell-Nr. und die Benennung angegeben werden. Ist dies nicht der Fall, kann die Bestellung nicht bearbeitet werden.

#### Bestellbeispiel:

Position (90), Motor kpl. = 40500.50.86, Motor kpl.

#### Important notice!

When ordering spare parts you must always state the order number and give the description. If you do not do this, the order cannot be processed.

#### Order example:

Position (90), Motor cpl. = 40500.50.86, Motor cpl.



Maßstabs- und originalgetreue Kleinmodelle für erwachsene Sammler.



Scale and true to original small-sized model for adult collectors.



Zum Betrieb des vorliegenden Produkts darf als Spannungsquelle nur ein nach VDE 0551/EN 60742 gefertigter Spielzeug-Transformator verwendet werden.

Only a toy transformer produced compliant with VDE 0551/EN 60742 may be used as a voltage source to operate this product.



Dieses Produkt entspricht den gültigen CE Normen.  
This product conforms to the current CE standards.



Elektro- und Elektronikaltgeräte dürfen nicht in den Hausmüll gelangen. Sie müssen entsprechend der jeweils gültigen Länderrichtlinien fachgerecht entsorgt werden.



Electrical equipment may not reach to domestic waste. According to the current terms of the country reference the electrical equipment must professional disposed.



Brawa Artur Braun Modellspielwarenfabrik GmbH & Co.  
Uferstraße 26-28 · D-73630 Remshalden  
Hotline 07151 - 979 35 68  
Telefax 07151 - 746 62  
[www.brawa.de](http://www.brawa.de)

40504.50.235 / 02.11 - BRA

