



Betriebsanleitung Diesellokomotive V100 – H0



Nach dem 2. Weltkrieg sollte bei der Deutschen Reichsbahn eine Diesellok mit Mittelstand in der mittleren Leistungsklasse veraltete Dampfloks ersetzen. Die Grundkonstruktion erarbeitete "Karl Marx" LKM in Babelsberg. Dort wurden auch die ersten Baumusterloks gefertigt. Den Prototyp zur Serienfertigung lieferte allerdings LEW Hans Beimler in Henningsdorf bei Berlin. Nach Erprobung und Beseitigung kleinerer Mängel setzte die Deutsche Reichsbahn die V 100 erfolgreich auf Nebenstrecken ein. Es entstand aber auch Bedarf an leistungsstarken Rangierloks. Wegen fehlender Liefer- und Entwicklungskapazitäten war es der Deutschen Reichsbahn nicht möglich, neue Lokomotiven zu bauen. Man entschloss sich deshalb zur Auf- und Umrüstung einzelner Exemplare der Baureihen 111 und 110. Die Zentralstelle Maschinenteknik der Deutschen Reichsbahn in Dessau wurde mit den erforderlichen Konstruktionsarbeiten beauftragt. 1991 begann dann der eigentliche Umbau. Als Baureihe 110 fuhr die V 100 vor der Wende mit schwarzen Schildern auf dem Gebiet der Deutschen Reichsbahn. Nach der Ausmusterung bei der Deutschen Reichsbahn finden viele der V 100 Loks ihre weitere Verwendung bei Privatbahnen. Die Firma TLG (Transport und Logistik Gesellschaft) hat mehrere V 100 im Einsatz. Im gesamten Bundesgebiet werden diese Loks als Bauzüge und im Güterdienst eingesetzt.





Operating instructions

Diesel locomotive V100 – H0

After the Second World War, a diesel locomotive with central driver's cab was to replace outdated steam locomotives in the medium performance range at the German State Railway (DR). The basic design was worked out by the LKM 'Karl Marx' in Babelsberg. That is also where the first model locomotives were manufactured. However, the prototype for series manufacture was supplied by the LEW 'Hans Beimler' in Henningsdorf near Berlin. After trials and the elimination of some minor defects, the German State Railway successfully used the V100 on branch lines. However, there was also a need for powerful shunting locomotives. Due to a lack of delivery and development capacities, the German State Railway was unable to build new locomotives. It was therefore decided to upgrade and retrofit individual locomotives in the 111 and 110 series. The German State Railway's main engineering headquarters in Dessau were commissioned with the necessary design work. The actual conversion work started in 1991. With black signboards, the V 100 operated as 110 series in the area of the German State Railway prior to the political turnaround in Germany. After having been taken out of service by the German State Railway, many of the V 100 locomotives continue to be used by private railways. The company TLG (Transport und Logistik Gesellschaft) is using several V 100. These locomotives are used as work trains and for the transportation of goods across the entire federal territory.





Inhaltsverzeichnis Contents



Benennung	Seite
Allgemeine Montage- und Sicherheitshinweise	4
Entnahme der Lok aus der Verpackung	5
Zusatzbauteile montieren	6
Wartungsarbeiten	
• 1. Ölen	7
• 2. Gehäuse demontieren	8
• 3. Platine tauschen	8
• 4. Beleuchtung	8
• 5. Motor tauschen	8
• 6. Wartungsarbeiten am oberen Getriebeteil	8
• 7. Wartungsarbeiten an Radsätzen, unterem Getriebeteil und Haftreifen tauschen	9
• 8. Kupplungsnormschacht tauschen	9
• 9. Schleifer tauschen bei AC Ausführung	9
• 10. Digitaldecoder tauschen bei AC Ausführung	9
• 11. Umrüsten auf Digitalbetrieb	10
Funktionstastenbelegung für Soundmodelle	10
Ersatzteilliste	
Gleichstrom- und Wechselstrom-Ausführung	16 – 20
Bestellbeispiel	20
Description	
General assembly and safety information	4
Removing the locomotive from the packaging	5
Fitting additional parts	6
Maintenance works	
• 1. Lubricating	7
• 2. Dismantling housing	12
• 3. Exchanging the circuit board	12
• 4. Lightning	12
• 5. Exchanging the motor	12
• 6. Maintenance work on the upper gear part	12
• 7. Maintenance work on wheel sets, exchanging lower gear part and traction tires	13
• 8. Exchanging coupler pocket	13
• 9. Exchanging the pick-up, alternating current	13
• 10. Exchanging the digital decoder in the alternating current model	13
• 11. Conversion to digital operation	14
Function keys for sound models	14
Spare parts list	
Direct current and alternating current	16 – 20
Order example	20





Arbeiten vor der Inbetriebnahme Work to be performed before starting up

Allgemeine Montage- und Sicherheitshinweise

- Diese Bedienungsanleitung beschreibt sämtliche Arbeitsvorgänge die zur Wartung und Instandhaltung notwendig sind. Bitte lesen Sie diese Bedienungsanleitung bevor Sie mit den Arbeiten beginnen.
- Bei unsachgemäßem Umgang mit elektrischen Bauteilen können diese zerstört werden. Für entsprechende Arbeiten (z.B. Platinenwechsel) können Sie sich an Ihren Fachhändler oder den Hersteller wenden.
- Bei den folgenden Wartungsarbeiten ist die jeweilige Demontage beschrieben, der Zusammenbau ist in umgekehrter Reihenfolge auszuführen.
- Die folgenden Wartungsarbeiten sind bei Gleich- und Wechselstrom-Ausführungen fast identisch. Im Ausnahmefall wird im entsprechenden Textabschnitt Bezug genommen.
- Jegliche Kabel oder Verbindungsdrähte die in diesem Produkt verbaut sind dürfen nicht in eine Netzsteckdose eingeführt werden. Lebensgefahr!



General assembly and safety information

- These operating instructions describe all work steps necessary for maintenance and repair. Please read these operating instructions carefully before you start with your work.
- In the case of incorrect handling of electrical components, they may be destroyed. Please ask your specialist dealer to help with the necessary work (e.g. changing circuit boards).
- In the case of maintenance work, the disassembly is described below, to re-assemble the tractor reverse the work steps.
- The maintenance work described below is virtually identical for direct current and alternating current models. If there are any differences these will be pointed out specifically.
- All cables and connection wires installed in this product may not be inserted in a mains socket. Danger!





Entnahme der Lok aus der Verpackung (Fig. 1)

Verpackung öffnen, Styropor mit Lokomotive herausziehen.
Lokomotive über 2 Öffnungen an der Unterseite aus der
Verpackung drücken.

Removing the locomotive from the packaging (Fig. 1)

Open the packaging, pull out polystyrene together with the
locomotive. Push locomotive from the packaging with the aid
of the two openings on the underside of the packaging.

Fig. 1

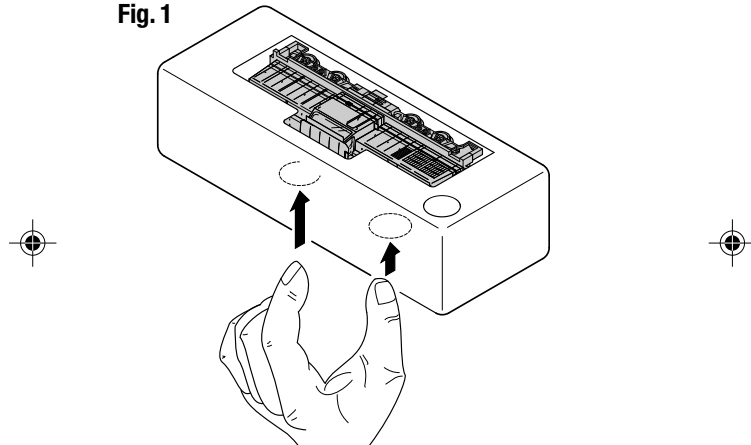



Zusatzbauteile montieren (Fig. 2)

In der Verpackung sind zusätzliche Bauteile lose beigelegt.

1 = 2x Bügelkupplung 2 = 4x Puffer

Werden die Bauteile aus dem Zurüstbeutel für Vitrinenmodelle montiert, ist die Lok nicht mehr für den Fahrbetrieb geeignet.

3 = 4x Luftschlauch links 5 = 2x Kupplungsimitat

4 = 4x Luftschlauch rechts

Fitting additional parts (Fig. 2)

Accessory parts have been loosely enclosed in the packaging.

1 = 2x Bow coupling 2 = 4x Buffer

If parts contained in the setting-up bag for showcase models are fitted, the locomotive is no longer suitable for running on tracks.

3 = 4x Air hose right 5 = 2x Imitation coupling

4 = 4x Air hose left

Fig. 2

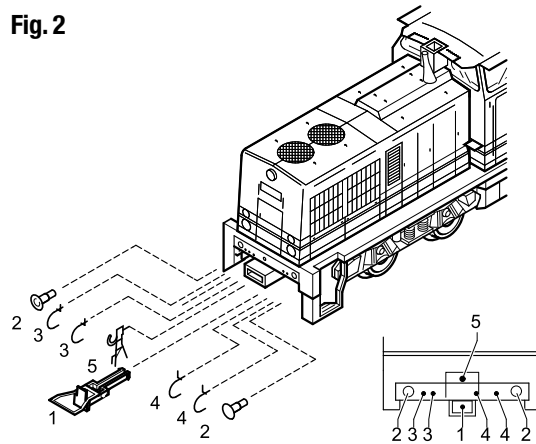



Wartungsarbeiten Maintenance works



1. Ölen (Fig. 3)

Der Motor und die Lagerstellen der Radsätze können an den gekennzeichneten Punkten sparsam mit Öl der Modellbaubranche geölt werden. Zum Ölen des Motors ist das Gehäuse abzunehmen, siehe Seite 8 Punkt 2.

1. Lubricating (Fig. 3)

The engine and the wheelset bearings may be sparingly lubricated at the marked places with oil used for model making purposes.

In order to lubricate the engine, remove the housing, compare page 12, item 2.

Fig. 3

Motor
Motor

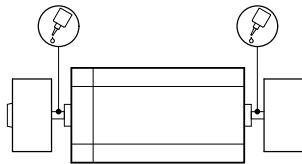

Räder
Wheels

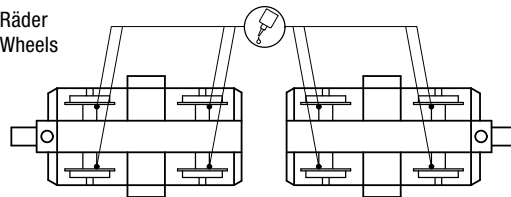



Wartungsarbeiten

2. Gehäuse demontieren (Fig. 4, Seite 11)

Führerstand (1) demontieren:

4 Halteclipe (2) mittels eines kleinen Schraubendrehers nach oben ausclipsen. Führerstand nach oben herausziehen.

Gehäuse vorn / hinten (3) demontieren:

Gehäuse leicht zusammendrücken, dadurch werden die Halteclipe (4) ausgeclipst. Gehäuse nach oben abnehmen.

3. Platine tauschen (Fig. 4, Seite 11)

Gehäuse abnehmen, siehe Punkt 2.

2 Befestigungsschrauben (5) herausdrehen. Platine (7) leicht kippen und die Stromzufuhrkabel (8) ablöten. Verkabelung des Motors (9) an Platine ablöten.

Hinweis:

Bitte kennzeichnen Sie sich wie die Kabel angeschlossen waren – sonst falsche Fahrtrichtung.

4. Beleuchtung

Diese Lokomotive ist mit wartungsfreien Leuchtdioden ausgestattet. Bei einem eventuellen Defekt der Leuchtdioden wenden Sie sich bitte an Ihren Fachhändler oder den Hersteller.

5. Motor tauschen (Fig. 4, Seite 11)

Gehäuse und Platine abnehmen, siehe Punkte 2 und 3.

Motorverkabelung (9) an Platine (7) ablöten. Befestigungsschrauben (8) vorne / hinten lösen und Gewichte (13 / 14) abnehmen. Drehgestellhalter (15) mit kleinem Schraubendreher ausclipsen. Schnecke (16) und Kardanwelle (17) aus Halterung entfernen. Drehgestell (18) nach unten abnehmen. Tank (19) an der Unterseite abziehen (ist mit Klebeband fixiert). Motorlagerungen (20) aus Bodenplatte (21) mit Schraubendreher nach oben ausknöpfen, Motor (22) mit beiden Motorlagerhälften herausnehmen.

Achtung: Bei Ausbau des Motors auf Einbaulage achten – sonst falsche Fahrtrichtung.

6. Wartungsarbeiten am oberen Getriebeteil (Fig. 4, Seite 11)

Gehäuse und Platine demontieren, siehe Punkte 2 bis 3.

Befestigungsschrauben (12) vorne / hinten lösen und Gewichte abnehmen. Drehgestellhalter (15) mit kleinem Schraubendreher ausclipsen. Schnecke (16) und Kardanwelle (17) aus Halterung entfernen.





7. Wartungsarbeiten an Radsätzen, unterem Getriebeteil und Haftreifen tauschen (Fig. 4, Seite 11)

Hinweis für Wechselstrom-Ausführung:

Vor dem Abnehmen der Getriebeabdeckung (23) muss der Schleifer (24) abgeschraubt werden.

Gehäuse und Platine demontieren, siehe Punkte 2 bis 3.
Getriebeteil ausbauen, siehe Punkt 6. Stromzufuhrkabel (8) von der Platine (7) entfernen, Drehgestellhalter (15) mit kleinem Schraubendreher ausclipsen. Schnecke (16) und Kardanwelle (17) aus Halterung entfernen. Das gesamte Drehgestell (18) kann jetzt nach unten herausgezogen werden. Drehgestellblenden (25) an einer Seite vorsichtig lösen, Getriebeabdeckung (23) mit kleinem Schraubendreher anheben und ausclipsen, jetzt sind die Zahnräder (26) zugänglich und die Radsätze (27) entnehmbar. Nun lassen sich auch die Haftreifen (28) wechseln.

8. Kupplungsnormschacht tauschen (Fig. 4, Seite 11)

Normschacht-Stecker (29) herausziehen, Kupplungsnormschacht (30) mit Kupplung (31) entnehmen. Kupplung aus Kupplungsnormschacht herausziehen.

9. Schleifer tauschen bei Wechselstrom-Ausführung (Fig. 4, Seite 11)

Befestigungsschraube (32) herausdrehen, Schleifer (13) lösen und Stromzufuhrkabel (35) an Schleifer ablöten.

10. Digitaldecoder tauschen (Fig. 4, Seite 11)

Gehäuse demontieren, siehe Punkt 2.
Digitaldecoder (33) abziehen und neuen einstecken.

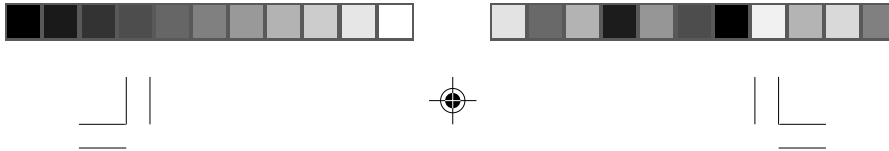

Wartungsarbeiten

11. Umrüsten auf Digitalbetrieb (Fig. 4, Seite 11)

Gleichstrom-Ausführung

Gehäuse abnehmen, Blindstecker (34) abziehen und Digital-Decoder (33) einstecken.

Den richtigen Einbau des Digitaldecoders und dessen Einsteckrichtung entnehmen Sie der Einbauvorschrift des Decoderherstellers.

Wechselstrom-Ausführung

Lokomotiven in Wechselstrom-Ausführung AC werden serienmäßig mit Premium-Digitaldecoder (33) ausgeliefert. Der Decoder erkennt die Betriebsart (analog/digital) selbstständig. Soll der Decoder umprogrammiert werden, liegt die Einbau- und Betriebsanleitung Premium-Digitaldecoder bei.

Der Decoder ist werkseitig auf Adresse 03 eingestellt.



Funktionstastenbelegung für Soundmodelle

- F0 Licht AN/AUS
- F1 Fahrgeräusch
- F2 Horn
- F3 Durchsage
- F4 Türen
- F5 Schaffnerpfeif
- F6 Rangiergang
- F7 Sanden
- F8 Diesel Fahrstufe auf
- F9 Diesel Fahrstufe ab
- F10 Kurzpfeif



Hinweis:

Wir bitten Sie genau darauf zu achten, wo und wie jedes Einzelteil montiert war. Die Einbaulage können Sie auch aus der Ersatzteilgrafik Seite 16 / 17 entnehmen.





BRAWA
LIEBE ZUM DETAIL

Fig. 4

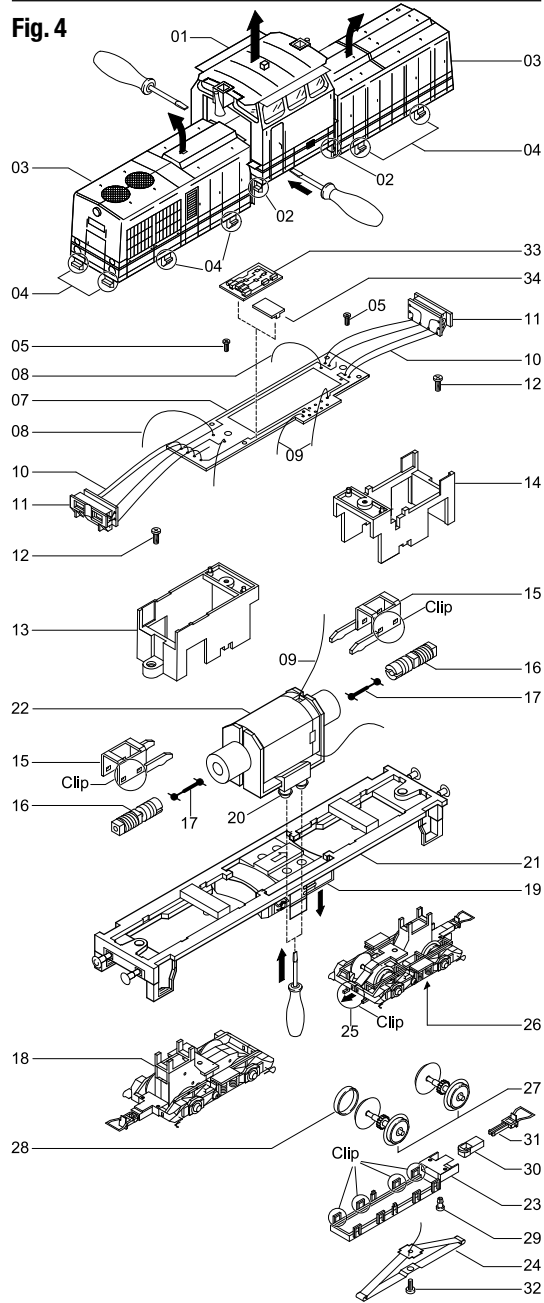



Maintenance works

2. Dismantling housing (Fig. 4, Page15)

Dismantle driver's cab (1):

Using a small screwdriver, unclip the 4 mounting clips by lifting upwards. Remove the driver's cab upwards.

Dismantling the casing front / back (3):

Slightly squeeze casing to release the mounting clips. Remove the casing upwards.

3. Exchanging the circuit board (Fig. 4, Page 15)

Remove casing, see item 2.

Unscrew the two mounting screws. Slightly tip the circuit board (7) and unsolder the power supply cable (8). Unsolder the cable from the motor (9) to the circuit board.

Note:

Make a note of how the cables were soldered. otherwise direction may be wrong.

4. Lighting

This locomotive is fitted with maintenance-free light-emitting diodes. If a defect occurs in the light-emitting diodes, please contact your specialist dealer or the manufacturer.

5. Exchanging the motor (Fig. 4, Page 15)

Remove housing and circuit board, see item 2 and 3.

Unsolder motor cables (9) from circuit board (7). Unscrew mounting screws (8) front / back and remove weights (13 / 14). Unclip bogie attachment (15) with a small screw driver. Remove endless screw (16) and cardan shaft (17) from their holders. Remove bogie (18) downwards. Pull tank (19) off the underside (fastened with adhesive tape). Using a screwdriver, push engine bearings (20) upwards from the bottom plate (21), remove engine (22) with both motor bearing halves.

Caution: When removing the engine, please note the installation position, otherwise direction may be wrong.

6. Maintenance work on the upper gear part (Fig. 4, Page 15)

Dismantle casing and circuit board, see item 2 to 3. Unscrew mounting screws (12) front / back and remove weights. Unclip the bogie attachment (15) with a small screwdriver. Remove endless screw (16) and cardan shaft (17) from holder.



7. Maintenance work on wheel sets, exchanging lower gear part and traction tires (Fig. 4, Page 15)

Note on alternating current models:

Bogie with pick-up is without propulsion. Before removing the gear cover (23) the pick-up (24) must be unscrewed.

Dismantle casing and circuit board, see item 2 to 3. Dismantle gear part, see item 6. Remove power supply cable (8) from circuit board. Unclip the bogie attachment (15) with a small screwdriver. Remove endless screw (16) and cardan shaft (17) from holder.

The whole bogie (18) can now be removed downwards. Release the bogie panels (25) carefully on one side, lift the gear cover (23) with a small screwdriver and unclip. Now you can access the tooth-wheels (26) and remove the wheel-sets (28). The traction tires can now be exchanged (28).

8. Exchanging coupler pocket (Fig. 4, Page 15)

Pull out coupler pocket pin (29), remove coupler pocket (30) with coupler (31). Pull out coupler from coupler pocket.

9. Exchanging the pick-up, alternating current (Fig. 4, Page 15)

Unscrew mounting screws (32), remove pick up (13) and unsolder power supply cable (35) from the pick-up.

10. Exchanging the digital decoder (Fig. 4, Page 15)

Remove housing, see item 2.

Pull out digital decoder (33) and insert new one.



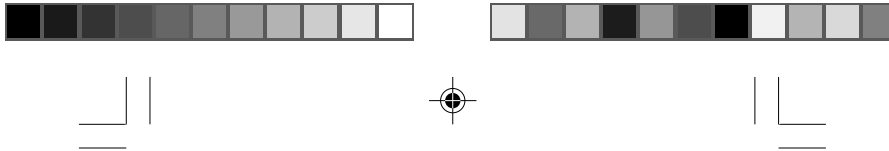

11. Conversion to digital operation (Fig. 4, Page 15)

DC version

Remove housing, pull off dummy connector (34) and insert digital decoder (33).

Please consult the installation instructions issued by the decoder manufacturer for correct installation of the digital decoder and its insert direction.

AC version

The premium digital decoder (33) is standard for the alternating current (AC) locomotives models. The decoder independently identifies the operation type (analog/digital). Please refer to the enclosed installation and operation instructions "Premium Digital Decoder" in the event that the decoder needs to be reprogrammed.

The decoder is set to address 03 in the factory.

Function keys for Soundmodels

- F0 Light ON/OFF
- F1 Sound ON/OFF
- F2 Horn
- F3 Announcement
- F4 Doors
- F5 Conductor signal
- F6 Shunting mode
- F7 Sanding
- F8 Diesel running notch up
- F9 Diesel running notch down
- F10 Short whistle

Note:

Please note exactly where and how each individual part was mounted. The mounting position is also indicated on the spart parts graph on page 16 / 17.



Maintenance works

Fig. 4

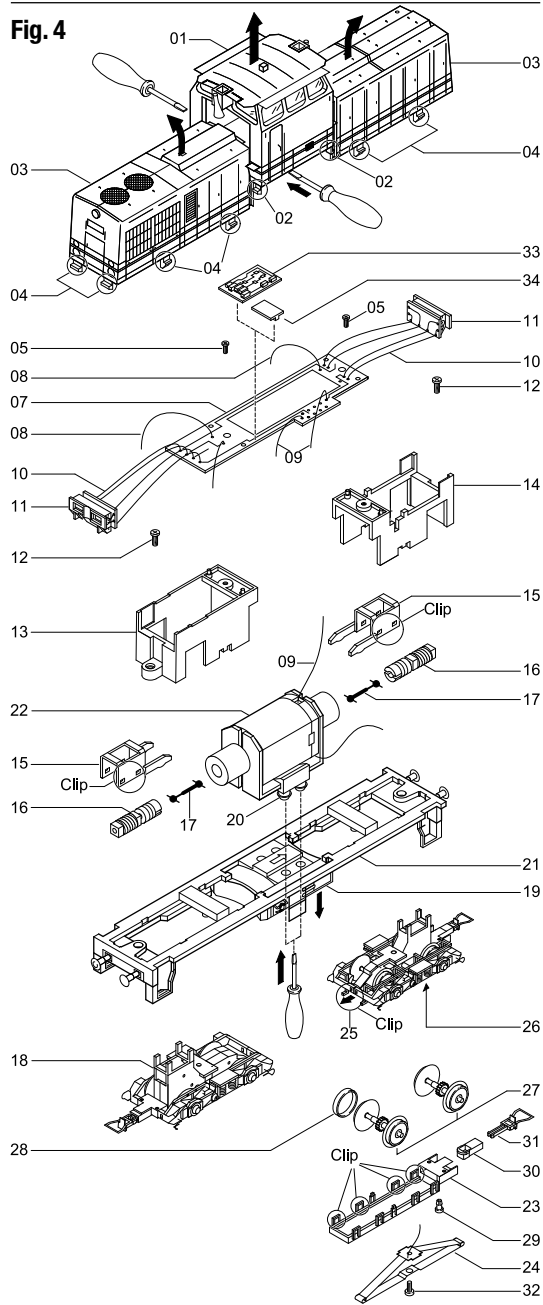



Ersatzteilliste Spare Parts List

Vorn / Front

Hinten / back

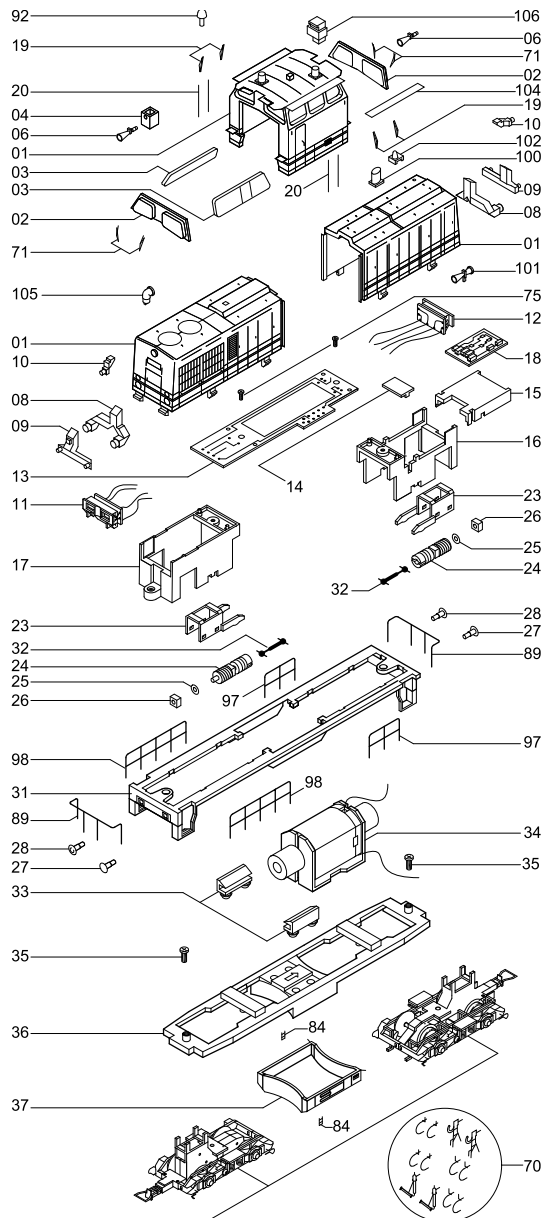

Drehgestell siehe Seite 17
Bogie see page 17





Drehgestell hinten

Bogie back

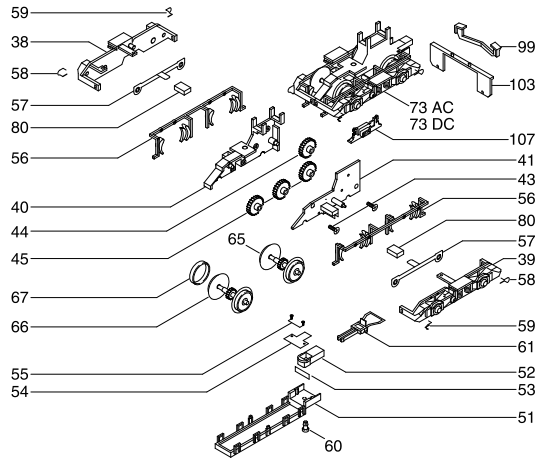

Drehgestell vorn

Bogie front

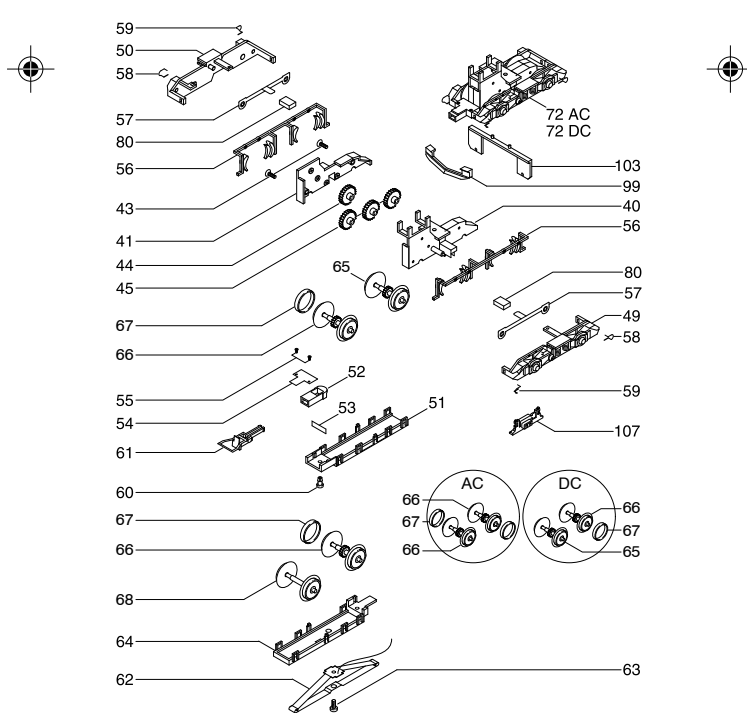



Ersatzteilliste Spare Parts List

Pos.	Bestell Nr. Order no.	Benennung	Description
01	41208.50.01	Gehäuse kpl.	Body cpl.
02	41000.50.02	Frontfenster	Front window
03	41000.50.03	Seitenfenster	Window side
04	41010.50.05	Kamin	Chimney
06	41010.50.06	Signalhorn	Signal horn
08	41000.50.08	Lichtleiter weiß	Light bar white
09	41000.50.09	Lichtleiter rot	Light bar red
10	41000.50.10	Lichtleiter oben	Light bar top
11	41010.50.11	Platine mit Lampen	PCB with bulbs
		Kabel kurz	short wire
12	41010.50.12	Platine mit Lampen	PCB with bulbs
		Kabel lang	long wire
13	41010.50.13	Platine	PCB
14*	41010.50.110	Blindstecker	Blind plug
16	41010.50.15	Gewicht hinten	Weight back
17	41010.50.16	Gewicht vorn	Weight front
18**	9750.50.80	Premium-Digitaldecoder	Premium digital decoder
	9750.50.82	Sounddecoder	Sounddecoder
	9750.51.95	Lautsprecher	Speaker
19	41000.50.17	Windabweiser	Wind shield
20	41000.50.18	Griffstangen Führerhaus	Handrail cabin
23	0415.50.21	Drehgestellhalter	Bogie holder
24	41010.50.22	Schnecke kpl.	Worm gear cpl.
25	0415.50.23	Lagerstein	Bearing for Worm gear
26	0415.50.24	Scheibe	Washer
27	41000.50.25	Puffer flach	Buffer flat
28	41000.50.26	Puffer gewölbt	Buffer round
31	41208.50.29	Umlauf	Main frame
32	41010.50.30	Kardanwelle	Cardan shaft
33	0415.50.31	Motorhalter	Motor holder
34	41010.50.32	Motor kpl.	Motor
35	0415.50.33	Schrauben für Rahmen	Screws for frame
36	41010.50.34	Rahmen	Frame
37	41208.50.35	Tankabdeckung	Tank cover
38	41208.50.36	Drehgestellblende rechts hinten kpl.	Boogie side frame right back cpl.
39	41208.50.37	Drehgestellblende links hinten kpl.	Boogie side frame left back cpl.
40	41010.50.38	Getriebegehäuse	Gearbox
41	41010.50.39	Getriebegehäuse	Gearbox
43	41010.50.41	Schrauben für Getriebegehäuse	Screw for gearbox
44	41010.50.42	Schneckenrad	Worm gear
45	41010.50.43	Zahnrad	Gear
49	41208.50.47	Drehgestellblende links vorne	Boogie side frame left front
50	41208.50.48	Drehgestellblende rechts vorne	Boogie side frame right front
51	0415.50.49	Getriebeabdeckung	Gear plate
52	41010.50.50	Normschacht	Coupler pocket
53	0201.01.23	Federplättchen	Spring for coupler

* Bauteil wird nur bei **Gleichstrom-Ausführung** verwendet.

** Bauteil wird nur bei **Wechselstrom-Ausführung** verwendet.

* Part is only used for the **DC version**.

** Part is only used for the **AC version**.





Pos.	Bestell Nr. Order no.	Benennung	Description
54	0415.50.51	Abdeckung für Normschacht	Cover for coupler
55	0415.50.52	Schrauben für Abdeckung	Screw for coupler
56	0422.50.53	Bremsanlage	Brake
57	0415.50.54	Achslagerung	Axle box
58	0422.50.55	Sandfallrohr rechts	Sandpipe right
59	0422.50.56	Sandfallrohr links	Sandpipe left
60	0415.50.57	Pin für Normschacht	Pin for coupler pocket
61	9952.50.03	Bügelkupplung	Coupler
62**	2225	Schleifer	Pic up shoe
63**	0231.01.30	Schraube für Schleifer	Screw for Pic up shoe
64**	0456.50.58	Getriebeabdeckung	Gear plate
65*	0415.50.59	Radsatz ohne Haftreifennut	Wheelset without traction tire
**	0445.50.59	Radsatz ohne Haftreifennut	Wheelset without preparing for traction tire
66*	0415.50.60	Radsatz mit Haftreifennut	Wheelset with preparing for traction tire
**	0445.50.60	Radsatz mit Haftreifennut	Wheelset with preparing for traction tire
67	0300.50.14	Haftreifen	Traction tire
68**	0445.50.62	Radsatz ohne Antrieb	Wheelset without traction
70	41002.50.64	Zurüstbeutel	Extra Parts
71	41000.50.65	Scheibenwischer	Wisher
72**	41209.50.66	Drehgestell kpl. mit Schleifer und Antrieb	Bogie cpl. with pic up shoe and traction
*	41208.50.66	Drehgestell kpl. langer Vorbau	Bogie cpl. long body
73**	41209.50.67	Drehgestell kpl. kurzer Vorbau	Bogie cpl. short body
*	41208.50.67	Drehgestell kpl. kurzer Vorbau	Bogie cpl. short body
75	0415.50.70	Schrauben für Platine	Screw for PCB
84	41010.50.79	Trittstufe am Tank	Step for tank
89	41002.50.84	Geländer	Handrail
97	41002.50.92	Geländer kurz	Handrail short
98	41002.50.93	Geländer lang	Handrail long
99	41000.50.94	Schienenräumer	Rail guard
100	41010.50.95	Antenne	Antenna
101	41010.50.101	Signalhorn	Signal horn
102	41010.50.102	Antenne	Antenna
103	41000.50.103	Platte für Schienenräumer	Rail guard support
104	41010.50.104	Sonnenblende	Sunshade
105	41010.50.105	Stützen	Support
106	41010.50.106	Verkleidung	Protector
107	41010.50.107	Indusi	Indusi

* Bauteil wird nur bei **Gleichstrom-Ausführung** verwendet.

** Bauteil wird nur bei **Wechselstrom-Ausführung** verwendet.

* Part is only used for the **DC version**.

** Part is only used for the **AC version**.



Wichtiger Hinweis!

Bei der Bestellung von Ersatzteilen muss die Bestell-Nr. und die Benennung angegeben werden. Ist dies nicht der Fall, kann die Bestellung nicht bearbeitet werden.

Important notice!

When ordering spare parts you must always state the order number and give the description. If you do not do this, the order cannot be processed.

Bestellbeispiel:

Position (34), Motor = 41010.50.32, Motor

Order example:

Position (34), Motor = 41010.50.32, Motor



Maßstabs- und originalgetreue Kleinmodelle für erwachsene Sammler.



Scale and true to original small-sized model for adult collectors.



Zum Betrieb des vorliegenden Produkts darf als Spannungsquelle nur ein nach VDE 0551/EN 60742 gefertigter Spielzeug-Transformator verwendet werden.
Only a toy transformer produced compliant with VDE 0551/EN 60742 may be used as a voltage source to operate this product.



Elektro- und Elektronikaltgeräte dürfen nicht in den Hausmüll gelangen. Sie müssen entsprechend der jeweils gültigen Länderrichtlinien fachgerecht entsorgt werden.



Electrical equipment may not reach to domestic waste. According to the current terms of the country reference the electrical equipment must professional disposed.



Brawa Artur Braun Modellspielwarenfabrik GmbH & Co.

Uferstraße 26-28 · D-73630 Remshalden

Telefon +49 (0)7151 - 979 35 68

Telefax +49 (0)7151 - 746 62

<http://www.brawa.de>

41208.50.110 / 11 10 - BRA

