



Betriebsanleitung Diesellokomotive V100 – H0



Nach dem 2. Weltkrieg sollte bei der Deutschen Reichsbahn eine Diesellok mit Mittelstand in der mittleren Leistungsklasse veraltete Dampfloks ersetzen. Die Grundkonstruktion erarbeitete "Karl Marx" LKM in Babelsberg. Dort wurden auch die ersten Baumusterloks gefertigt. Den Prototyp zur Serienfertigung lieferte allerdings LEW Hans Beimler in Henningsdorf bei Berlin. Nach Erprobung und Beseitigung kleinerer Mängel setzte die Deutsche Reichsbahn die V100 erfolgreich auf Nebenstrecken ein. Es entstand aber auch Bedarf an leistungsstarken Rangierloks. Wegen fehlender Liefer- und Entwicklungskapazitäten war es der Deutschen Reichsbahn nicht möglich, neue Lokomotiven zu bauen. Man entschloss sich deshalb zur Auf- und Umrüstung einzelner Exemplare der Baureihen 111 und 110. Die Zentralstelle Maschinenteknik der Deutschen Reichsbahn in Dessau wurde mit den erforderlichen Konstruktionsarbeiten beauftragt. 1991 begann dann der eigentliche Umbau. Als Baureihe 110 fuhr die V100 vor der Wende mit schwarzen Schildern auf dem Gebiet der Deutschen Reichsbahn. Nach der Ausmusterung bei der Deutschen Reichsbahn finden viele der V100 Loks ihre weitere Verwendung bei Privatbahnen. Die Firma TLG (Transport und Logistik Gesellschaft) hat mehrere V100 im Einsatz. Im gesamten Bundesgebiet werden diese Loks als Bauzüge und im Güterdienst eingesetzt.





Operating instructions

Diesel locomotive V100 – H0

After the Second World War, a diesel locomotive with central driver's cab was to replace outdated steam locomotives in the medium performance range at the German State Railway (DR). The basic design was worked out by the LKM 'Karl Marx' in Babelsberg. That is also where the first model locomotives were manufactured. However, the prototype for series manufacture was supplied by the LEW 'Hans Beimler' in Henningsdorf near Berlin. After trials and the elimination of some minor defects, the German State Railway successfully used the V100 on branch lines. However, there was also a need for powerful shunting locomotives. Due to a lack of delivery and development capacities, the German State Railway was unable to build new locomotives. It was therefore decided to upgrade and retrofit individual locomotives in the 111 and 110 series. The German State Railway's main engineering headquarters in Dessau were commissioned with the necessary design work. The actual conversion work started in 1991. With black signboards, the V100 operated as 110 series in the area of the German State Railway prior to the political turnaround in Germany. After having been taken out of service by the German State Railway, many of the V100 locomotives continue to be used by private railways. The company TLG (Transport und Logistik Gesellschaft) is using several V100. These locomotives are used as work trains and for the transportation of goods across the entire federal territory.





Inhaltsverzeichnis Contents



Benennung	Seite
Allgemeine Montage- und Sicherheitshinweise	4
Entnahme der Lok aus der Verpackung	5
Zusatzbauteile montieren	6
Wartungsarbeiten	
• 1. Ölen	7
• 2. Gehäuse demontieren	8
• 3. Platine tauschen	8
• 4. Beleuchtung	8
• 5. Motor tauschen	8
• 6. Wartungsarbeiten am oberen Getriebeteil	8
• 7. Wartungsarbeiten an Radsätzen, unterem Getriebeteil und Haftreifen tauschen	9
• 8. Kupplungsnormschacht tauschen	9
• 9. Digitaldecoder tauschen	9
• 10. Umrüsten auf Digitalbetrieb	10
Ersatzteilliste	
Gleichstrom-Ausführung	16 – 19
Bestellbeispiel	19
Description	
General assembly and safety information	4
Removing the locomotive from the packaging	5
Fitting additional parts	6
Maintenance works	
• 1. Lubricating	7
• 2. Dismantling housing	12
• 3. Exchanging the circuit board	12
• 4. Lighting	12
• 5. Exchanging the motor	12
• 6. Maintenance work on the upper gear part	12
• 7. Maintenance work on wheel sets, exchanging lower gear part and traction tires	13
• 8. Exchanging coupler pocket	13
• 9. Exchanging the digital decoder	13
• 10. Conversion to digital operation	14
Spare parts list	
Direct current	16 – 19
Order example	19





Arbeiten vor der Inbetriebnahme **Work to be performed before starting up**

Allgemeine Montage- und Sicherheitshinweise

- Diese Bedienungsanleitung beschreibt sämtliche Arbeitsvorgänge die zur Wartung und Instandhaltung notwendig sind. Bitte lesen Sie diese Bedienungsanleitung bevor Sie mit den Arbeiten beginnen.
- Bei unsachgemäßem Umgang mit elektrischen Bauteilen können diese zerstört werden. Für entsprechende Arbeiten (z.B. Platinenwechsel) können Sie sich an Ihren Fachhändler oder den Hersteller wenden.
- Bei den folgenden Wartungsarbeiten ist die jeweilige Demontage beschrieben, der Zusammenbau ist in umgekehrter Reihenfolge auszuführen.
- Jegliche Kabel oder Verbindungsdrähte die in diesem Produkt verbaut sind dürfen nicht in eine Netzsteckdose eingeführt werden. Lebensgefahr!

General assembly and safety information

- These operating instructions describe all work steps necessary for maintenance and repair. Please read these operating instructions carefully before you start with your work.
- In the case of incorrect handling of electrical components, they may be destroyed. Please ask your specialist dealer to help with the necessary work (e.g. changing circuit boards).
- In the case of maintenance work, the disassembly is described below, to re-assemble the tractor reverse the work steps.
- All cables and connection wires installed in this product may not be inserted in a mains socket. Danger!





Entnahme der Lok aus der Verpackung (Fig. 1)

Verpackung öffnen, Styropor mit Lokomotive herausziehen.
Lokomotive über 2 Öffnungen an der Unterseite aus der
Verpackung drücken.

Removing the locomotive from the packaging (Fig. 1)

Open the packaging, pull out polystyrene together with the
locomotive. Push locomotive from the packaging with the aid
of the two openings on the underside of the packaging.

Fig. 1

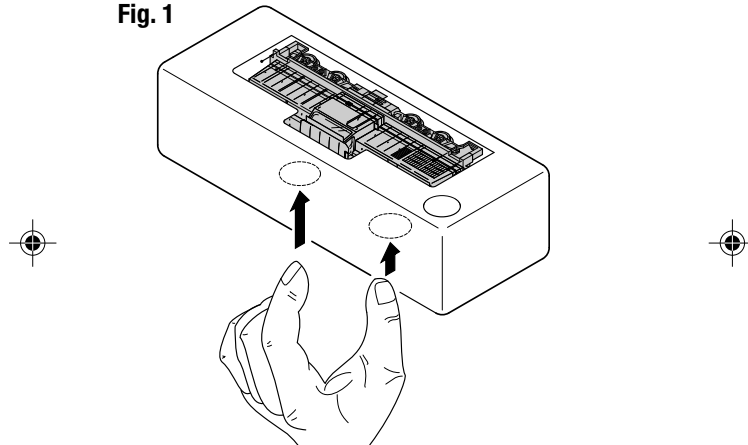



Zusatzbauteile montieren (Fig. 2)

In der Verpackung sind zusätzliche Bauteile lose beigelegt.

1 = 2x Bügelkupplung 2 = 4x Puffer

Werden die Bauteile aus dem Zurüstbeutel für Vitrinenmodelle montiert, ist die Lok nicht mehr für den Fahrbetrieb geeignet.

3 = 4x Luftschlauch links 5 = 2x Heizschlauch

4 = 4x Luftschlauch rechts 6 = 2x Kupplungsimitat

Fitting additional parts (Fig. 2)

Accessory parts have been loosely enclosed in the packaging.

1 = 2x bow coupling 2 = 4x Buffer

If parts contained in the setting-up bag for showcase models are fitted, the locomotive is no longer suitable for running on tracks.

3 = 4x air hose right 5 = 2x heating hose

4 = 4x air hose left 6 = 2x imitation coupling

Fig. 2

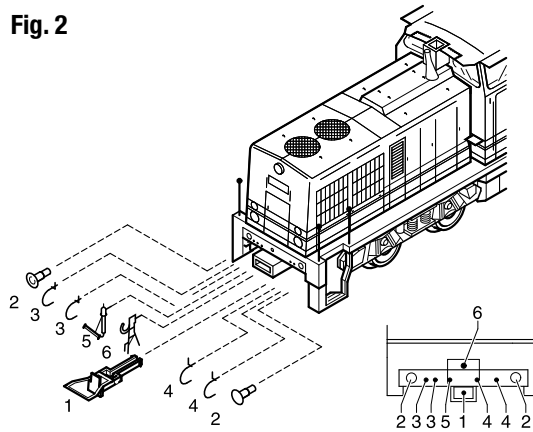



Wartungsarbeiten Maintenance works



1. Ölen (Fig. 3)

Der Motor und die Lagerstellen der Radsätze können an den gekennzeichneten Punkten sparsam mit Öl der Modellbaubranche geölt werden. Zum Ölen des Motors ist das Gehäuse abzunehmen, siehe Seite 8 Punkt 2.

1. Lubricating (Fig. 3)

The engine and the wheelset bearings may be sparingly lubricated at the marked places with oil used for model making purposes. In order to lubricate the engine, remove the housing, compare page 12, item 2.

Fig. 3

Motor
Motor

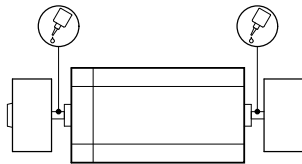

Räder
Wheels

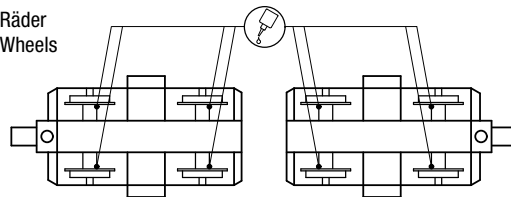



Wartungsarbeiten

2. Gehäuse demontieren (Fig. 4, Seite 11)

Führerstand (1) demontieren:

4 Halteclipse (2) mittels eines kleinen Schraubendrehers nach oben ausclipsen. Führerstand nach oben herausziehen.

Gehäuse vorn / hinten (3) demontieren:

Gehäuse leicht zusammendrücken, dadurch werden die Halteclipse (4) ausgeclipst. Gehäuse nach oben abnehmen.

3. Platine tauschen (Fig. 4, Seite 11)

Gehäuse abnehmen, siehe Punkt 2.

2 Befestigungsschrauben (5). Platine (7) leicht kippen und die Stromzufuhrkabel (8) ablöten. Verkabelung des Motors (9) an Platine ablöten.

Hinweis:

Bitte kennzeichnen Sie sich wie die Kabel angeschlossen waren – sonst falsche Fahrtrichtung.

4. Beleuchtung

Diese Lokomotive ist mit wartungsfreien Leuchtdioden ausgestattet. Bei einem eventuellen Defekt der Leuchtdioden wenden Sie sich bitte an Ihren Fachhändler oder den Hersteller.



5. Motor tauschen (Fig. 4, Seite 11)

Gehäuse und Platine abnehmen, siehe Punkte 2 und 3. Motorverkabelung (9) an Platine (7) ablöten. Befestigungsschrauben (8) vorne / hinten lösen und Gewichte (13 / 14) abnehmen.

Drehgestellhalter (15) mit kleinem Schraubendreher ausclipsen. Schnecke (16) und Kardanwelle (17) aus Halterung entfernen. Drehgestell (18) nach unten abnehmen. Tank (19) an der Unterseite abziehen (ist mit Klebeband fixiert). Motorlagerungen (20) aus Bodenplatte (21) mit Schraubendreher nach oben ausknöpfen, Motor (22) mit beiden Motorlagerhälften herausnehmen.

Achtung: Bei Ausbau des Motors auf Einbaulage achten – sonst falsche Fahrtrichtung.

6. Wartungsarbeiten am oberen Getriebeteil (Fig. 4, Seite 11)

Gehäuse und Platine demontieren, siehe Punkte

2 bis 3. Befestigungsschrauben (12) vorne / hinten lösen und Gewichte abnehmen. Drehgestellhalter (15) mit kleinem Schraubendreher ausclipsen. Schnecke (16) und Kardanwelle (17) aus Halterung entfernen.





7. Wartungsarbeiten an Radsätzen, unterem Getriebeteil und Haftreifen tauschen (Fig. 4, Seite 11)

Hinweis für Wechselstrom-Ausführung:

Vor dem Abnehmen der Getriebeabdeckung (23) muss der Schleifer (24) abgeschraubt werden.

Gehäuse und Platine demontieren, siehe Punkte 2 bis 3. Getriebeteil ausbauen, siehe Punkt 6. Stromzufuhrkabel (8) von der Platine (7) entfernen, Drehgestellhalter (15) mit kleinem Schraubendreher ausclipsen. Schnecke (16) und Kardanwelle (17) aus Halterung entfernen. Das gesamte Drehgestell (18) kann jetzt nach unten herausgezogen werden. Drehgestellblenden (25) an einer Seite vorsichtig lösen, Getriebeabdeckung (23) mit kleinem Schraubendreher anheben und ausclipsen, jetzt sind die Zahnräder (26) zugänglich und die Radsätze (27) entnehmbar. Nun lassen sich auch die Haftreifen (28) wechseln.

8. Kupplungsnormschacht tauschen (Fig. 4, Seite 11)



Normschacht-Stecker (29) herausziehen, Kupplungsnormschacht (30) mit Kupplung (31) entnehmen. Kupplung aus Kupplungsnormschacht herausziehen.



9. Digitaldecoder tauschen (Fig. 4, Seite 11)

Gehäuse demontieren, siehe Punkt 2.
Digitaldecoder (33) abziehen und neuen einstecken.





Wartungsarbeiten

10. Umrüsten auf Digitalbetrieb (Fig. 4, Seite 11)

Gleichstrom-Ausführung

Gehäuse abnehmen, Blindstecker (34) abziehen und Digital-Decoder (33) einstecken.

Den richtigen Einbau des Digitaldecoders und dessen Einsteckrichtung entnehmen Sie der Einbauvorschrift des Decoderherstellers.

Wechselstrom-Ausführung

Lokomotiven in Wechselstrom-Ausführung AC werden serienmäßig mit Premium-Digitaldecoder (33) ausgeliefert. Der Decoder erkennt die Betriebsart (analog/digital) selbstständig. Soll der Decoder umprogrammiert werden, liegt die Einbau- und Betriebsanleitung Premium-Digitaldecoder bei.

Der Decoder ist werkseitig auf Adresse 03 eingestellt.



Funktionstastenbelegung für Soundmodelle



- F0 Licht an/aus
- F1 Sound an/aus
- F2 Signalhorn 1
- F3 Ventilator während der Fahrt an/aus
- F4 Schaltbares Schlusslicht
- F5 Kupplung/Entkupplung Geräusch
- F6 Rangiergang
- F7 Schmierpumpe
- F8 Kompressor
- F9 Sanden
- F10 Bremse
- F11 Signalhorn kurz
- F12 Schaltstufe hoch/runter
- F13 Sicherheitsventil
- F14 Ventilator manuell ein/aus

Hinweis:

Wir bitten Sie genau darauf zu achten, wo und wie jedes Einzelteil montiert war. Die Einbaulage können Sie auch aus der Ersatzteilgrafik Seite 16 / 17 entnehmen.





Fig. 4

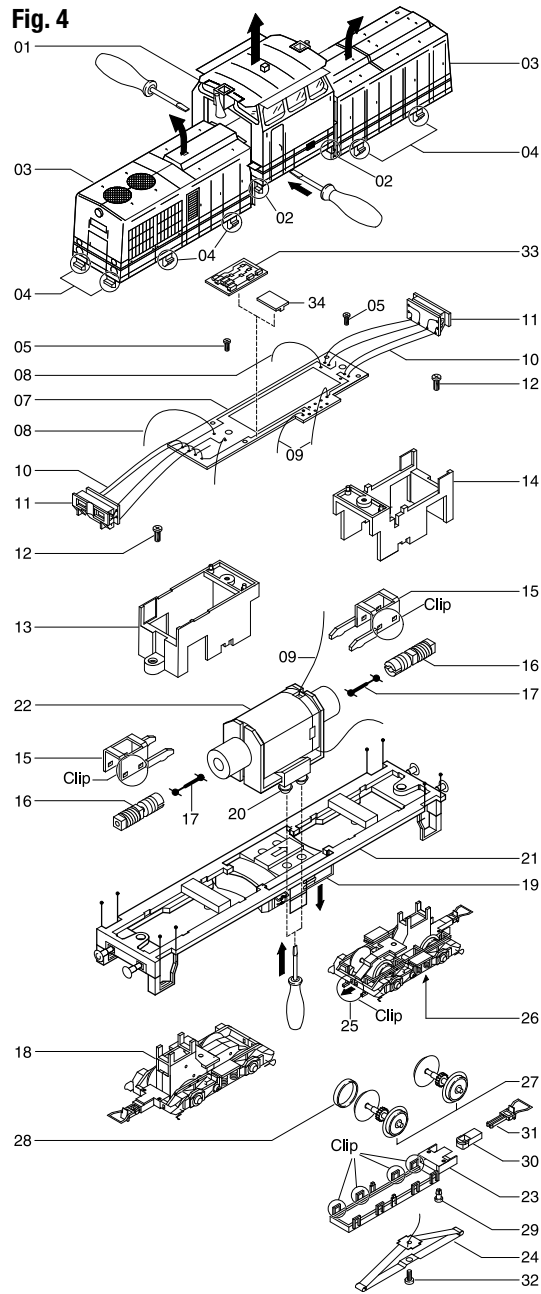



Maintenance works

2. Dismantling housing (Fig. 4, Page15)

Dismantle driver's cab (1):

Using a small screwdriver, unclip the 4 mounting clips by lifting upwards. Remove the driver's cab upwards.

Dismantling the casing front / back (3):

Slightly squeeze casing to release the mounting clips. Remove the casing upwards.

3. Exchanging the circuit board (Fig. 4,Page 15)

Remove casing, see item 2.

Unscrew the two mounting screws. Slightly tip the circuit board (7) and unsolder the power supply cable (8). Unsolder the cable from the motor (9) to the circuit board.

Note:

Make a note of how the cables were soldered. Otherwise direction may be wrong.

4. Lighting

This locomotive is fitted with maintenance-free light-emitting diodes. If a defect occurs in the light-emitting diodes, please contact your specialist dealer or the manufacturer.

5. Exchanging the motor (Fig. 4, Page 15)

Remove housing and circuit board, see item 2 and 3.

Unsolder motor cables (9) from circuit board (7). Unscrew mounting screws (8) front / back and remove weights

(13 / 14). Unclip bogie attachment (15) with a small screw driver.

Remove endless screw (16) and cardan shaft (17) from their

holders. Remove bogie (18) downwards. Pull tank (19) off the

underside (fastened with adhesive tape). Using a screwdriver, push engine bearings (20) upwards from the bottom plate (21), remove engine (22) with both motor bearing halves.

Caution: When removing the engine, please note the installation position, otherwise direction may be wrong.

6. Maintenance work on the upper gear part (Fig. 4, Page 15)

Dismantle casing and circuit board, see item 2 to 3. Unscrew mounting screws (12) front / back and remove weights. Unclip the bogie attachment (15) with a small screwdriver. Remove endless screw (16) and cardan shaft (17) from holder.





7. Maintenance work on wheel sets, exchanging lower gear part and traction tires (Fig. 4, Page 15)

Note on alternating current models:

Bogie with pick-up is without propulsion. Before removing the gear cover (23) the pick-up (24) must be unscrewed.

Dismantle casing and circuit board, see item 2 to 3. Dismantle gear part, see item 6. Remove power supply cable (8) from circuit board. Unclip the bogie attachment (15) with a small screwdriver. Remove endless screw (16) and cardan shaft (17) from holder. The whole bogie (18) can now be removed downwards. Release the bogie panels (25) carefully on one side, lift the gear cover (23) with a small screwdriver and unclip. Now you can access the tooth-wheels (26) and remove the wheel-sets (28). The traction tires can now be exchanged (28).

8. Exchanging coupler pocket (Fig. 4, Page 15)

Pull out coupler pocket pin (29), remove coupler pocket (30) with coupler (31). Pull out coupler from coupler pocket.

9. Exchanging the digital decoder (Fig. 4, Page 15)

Remove housing, see item 2.

Pull out digital decoder (33) and insert new one.



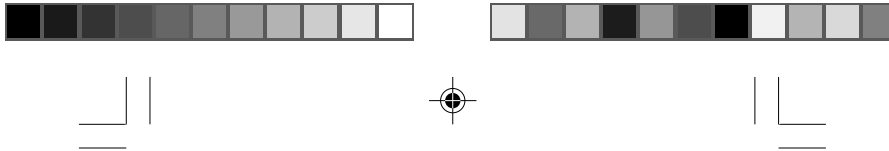

Maintenance works

10. Conversion to digital operation (Fig. 4, Page 15)

DC version

Remove housing, pull off dummy connector (34) and insert digital decoder (33).

Please consult the installation instructions issued by the decoder manufacturer for correct installation of the digital decoder and its insert direction.

AC version

The premium digital decoder (33) is standard for the alternating current (AC) locomotives models. The decoder independently identifies the operation type (analog/digital). Please refer to the enclosed installation and operation instructions "Premium Digital Decoder" in the event that the decoder needs to be reprogrammed.

The decoder is set to address 03 in the factory.



Function keys for Soundmodels



- F0 Light ON/OFF
- F1 Sound ON/OFF
- F2 Airhorn 1
- F3 Ventilator while driving ON/OFF
- F4 AUX 2 forward/AUX 1 backward
- F5 Coupling/Decoupling procedure
- F6 Shunting mode
- F7 Greasing
- F8 Compressor
- F9 Sanding
- F10 Brake
- F11 Airhorn short
- F12 Diesel notch up/down
- F13 Safety Valve
- F14 Ventilator manual ON/OFF

Note:

Please note exactly where and how each individual part was mounted. The mounting position is also indicated on the spart parts graph on page 16 / 17.





Fig. 4

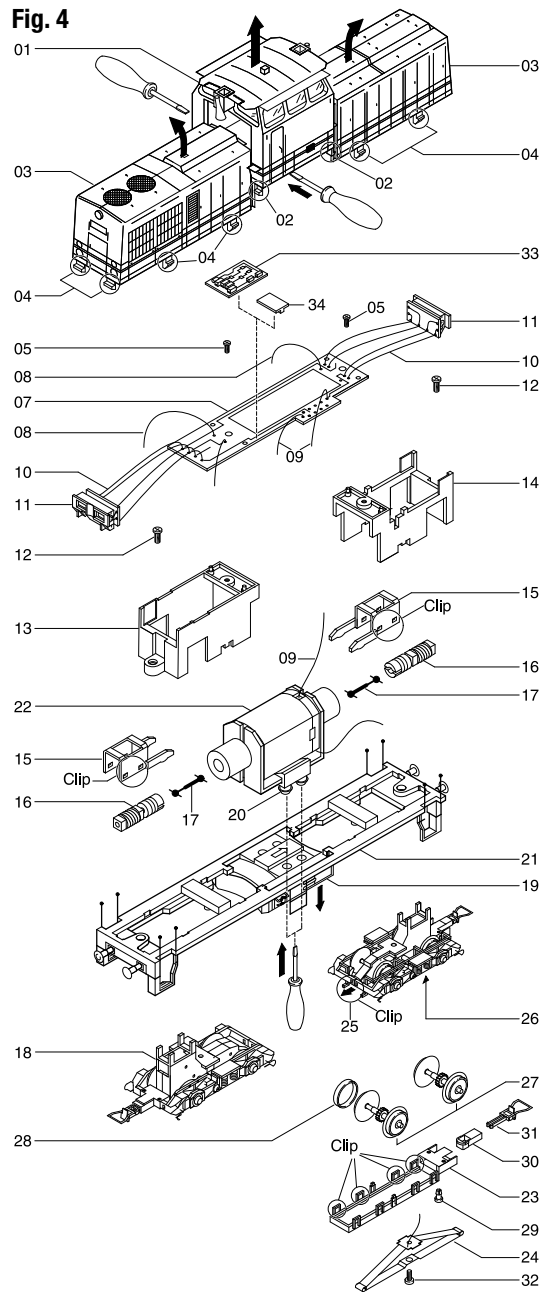



Ersatzteilliste Spare Parts List

Vorn / Front

Hinten / back

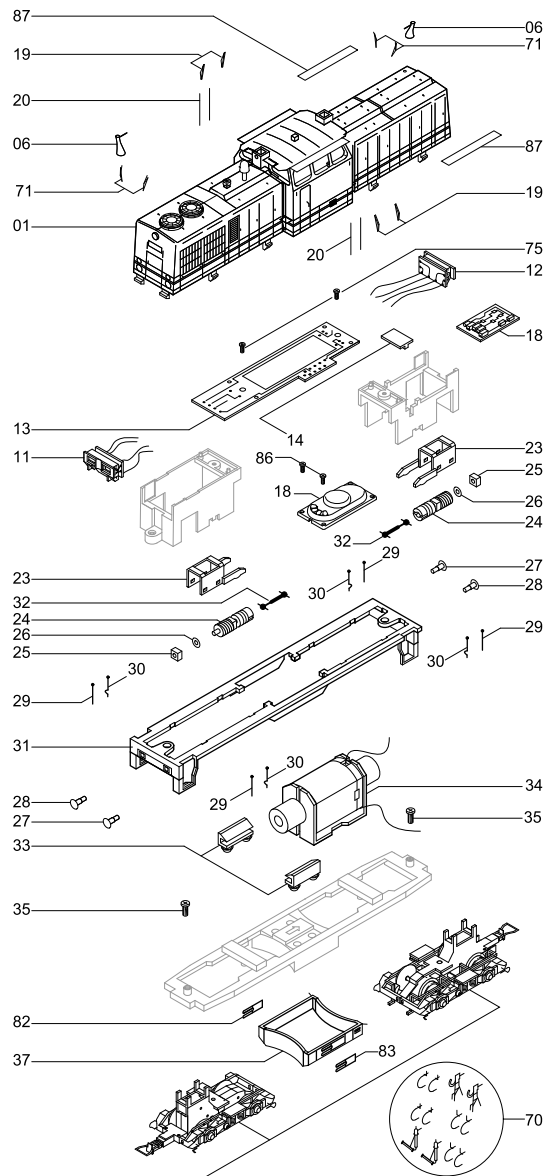

Drehgestell siehe Seite 17
Bogie see page 17





Drehgestell hinten

Bogie back

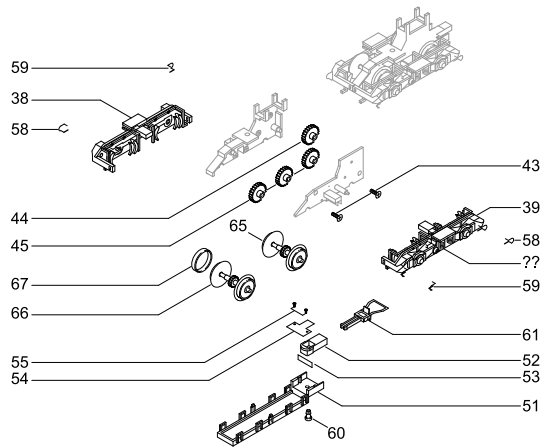

Drehgestell vorn

Bogie front

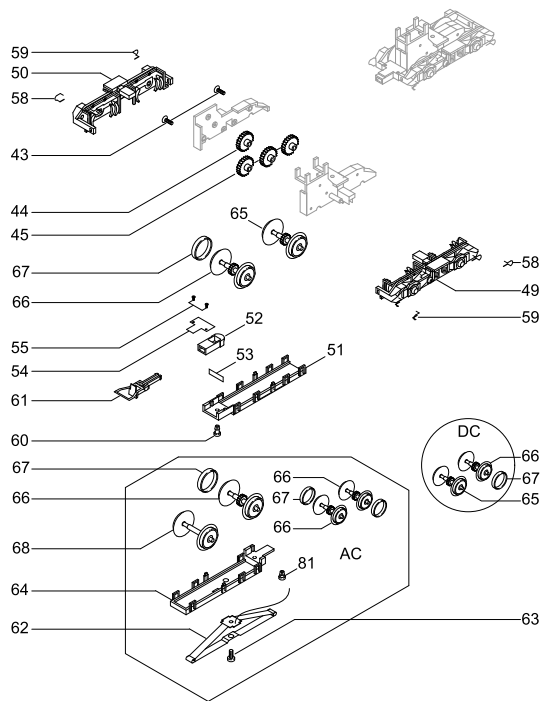



Ersatzteilliste Spare Parts List

Pos.	Bestell Nr. Order no.	Benennung	Description
01	41216.50.01	Gehäuse kpl.	Body cpl
06	41216.50.06	Signalhorn	Signal horn
11	41010.50.11	Platine mit Lampen Kabel kurz	PCB with bulbs short wire
12	41010.50.12	Platine mit Lampen Kabel lang	PCB with bulbs long wire
13	41028.50.13	Platine	PCB
14	41010.50.110	Blindstecker	Blind plug
18	9750.50.84	Premium-Digitaldecoder	Premium digital decoder
	9750.50.86	Sounddecoder	Sounddecoder
	9750.51.102	Lautsprecher	Speaker
19	0415.50.17	Windabweiser	Wind shield
20	0415.50.18	Griffstangen Führerhaus	Handrail cabin
23	0415.50.21	Drehgestellhalter	Bogie holder
24	41010.50.22	Schnecke kpl.	Worm gear cpl.
25	0415.50.23	Lagerstein	Bearing for Worm gear
26	0415.50.24	Scheibe	Washer
27	41216.50.25	Puffer flach	Buffer flat
28	41216.50.26	Puffer gewölbt	Buffer round
29	41216.50.27	Griffstange gerade	Handrail straight
30	41216.50.28	Griffstange gebogen	Handrail curved
31	41216.50.29	Umlauf	Main frame
32	41010.50.30	Kardanwelle	Cardan shaft
33	0415.50.31	Motorhalter	Motor holder
34	41010.50.32	Motor kpl.	Motor
35	0415.50.33	Schrauben für Rahmen	Screws for frame
37	41216.50.35	Tankabdeckung	Tank cover
38	41216.50.36	Drehgestellblende rechts hinten kpl.	Boogie side frame right back cpl.
39	41216.50.37	Drehgestellblende links hinten kpl.	Boogie side frame left back cpl.
43	41010.50.41	Schrauben für Getriebegehäuse	Screw for gearbox
44	41010.50.42	Schneckenrad	Worm gear
45	41010.50.43	Zahnrad	Gear
49	41216.50.47	Drehgestellblende links vorne kpl.	Boogie side frame left front cpl.
50	41216.50.48	Drehgestellblende rechts vorne kpl.	Boogie side frame right front cpl.
51	41216.50.49	Getriebeabdeckung	Gear plate
52	41216.50.50	Normschacht	Coupler pocket
53	0201.01.23	Federplättchen	Spring for coupler
54	41216.50.51	Abdeckung für Normschacht	Cover for coupler
55	0415.50.52	Schrauben für Abdeckung	Screw for coupler
58	41216.50.55	Sandfallrohr rechts	Sandpipe right
59	41216.50.56	Sandfallrohr links	Sandpipe left
60	41216.50.57	Pin für Normschacht	Pin for coupler pocket
61	9952.50.03	Bügelkupplung	Coupler
62	2225	Schleifer	Pic up shoe
63	0231.01.30	Schraube für Schleifer	Screw for pic up shoe
64	41217.50.58	Getriebeabdeckung	Gear plate
65	0415.50.59	Radsatz ohne Haftreifennut DC	Wheelset without traction tire DC
	0445.50.59	Radsatz ohne Haftreifennut AC	Wheelset without traction tire AC





Pos.	Bestell Nr. Order no.	Benennung	Description
66	0415.50.60	Radsatz mit Haftreifennut DC	Wheelset with preparing for traction tire DC
	0445.50.60	Radsatz mit Haftreifennut AC	Wheelset with preparing for traction tire AC
67	0300.50.14	Haftreifen	Traction tire
68	0445.50.62	Radsatz ohne Antrieb	Wheelset without traction
70	41216.50.64	Zurüstbeutel	Extra Parts
71	0417.50.65	Scheibenwischer	Wisher
75	0415.50.70	Schrauben für Platine	Screw for PCB
81	41217.50.76	Pin für Normschacht	Pin for coupler pocket
82	0426.50.77	Kühlleitung am Tank lang	Tank pipe long
83	0421.50.78	Kühlleitung am Tank kurz	Tank pipe short
86	41010.50.80	Schraube für Lautsprecher	Screw for speaker
87	41216.50.94	Sonnenblende	Sunshade

Wichtiger Hinweis!

Bei der Bestellung von Ersatzteilen muss die Bestell-Nr. und die Benennung angegeben werden. Ist dies nicht der Fall, kann die Bestellung nicht bearbeitet werden.

Important notice!

When ordering spare parts you must always state the order number and give the description. If you do not do this, the order cannot be processed.

Bestellbeispiel:

Position (34), Motor = 41010.50.32, Motor

Order example:

Position (34), Motor = 41010.50.32, Motor





HO

Maßstabs- und originalgetreue Kleinmodelle für erwachsene Sammler.



Scale and true to original small-sized model for adult collectors.



Zum Betrieb des vorliegenden Produkts darf als Spannungsquelle nur ein nach VDE 0551/EN 60742 gefertigter Spielzeug-Transformator verwendet werden. Only a toy transformer produced compliant with VDE 0551/EN 60742 may be used as a voltage source to operate this product.

CE



Elektro- und Elektronikaltgeräte dürfen nicht in den Hausmüll gelangen. Sie müssen entsprechend der jeweils gültigen Länderrichtlinien fachgerecht entsorgt werden.



Electrical equipment may not reach to domestic waste. According to the current terms of the country reference the electrical equipment must professional disposed.



Brawa Artur Braun Modellspielwarenfabrik GmbH & Co.
Uferstraße 26-28 · D-73630 Remshalden
Telefon +49 (0)7151 - 979 35 68
Telefax +49 (0)7151 - 746 62
www.brawa.de

41216.50.100 / 05.11 - BRA

