

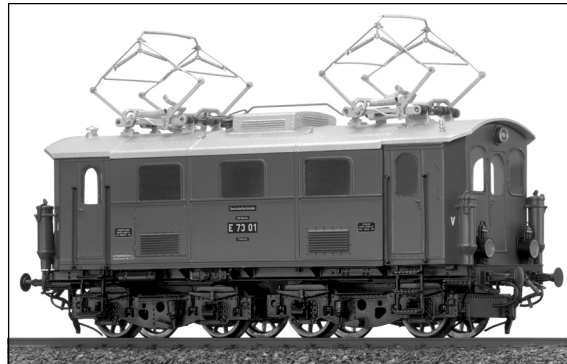

Betriebsanleitung E 73 – H0



Die beiden bayrischen EG 4X1/1 waren nach dem ersten Weltkrieg noch vorhanden und wurden von der Deutschen Reichsbahn, Gruppenverwaltung Bayern übernommen. Ab 1923 wurde die komplizierte Bezeichnung durch das einfachere EG 1 ersetzt, bei der DRG erhielten sie dann ab 1926 die Baureihe E 73 zugewiesen. Die beiden Loks waren immer in Freilassing beheimatet, neben ihrer Stammstrecke wurden sie auch im Rangierdienst in Salzburg verwendet. Offenbar war man auch bei der DRG mit ihnen sehr zufrieden, denn erst 1937 und 1941 schieden sie aus dem Dienst. Eine der beiden Loks wurde zu einem Schneepflug umgebaut, der dann noch lange Jahre treue Dienste leistete.



Operating instructions E 73 – H0



The two Bavarian EG 4 X 1/1 still existed after the First World War and had been taken over by the Deutsche Reichsbahn district management Bavaria. After 1923 the complex designation was replaced by a simple EG 1 and after 1926 they were then allocated the E 73 series for the DRG. Both locomotives were always based in Freilassing, in addition to their regular route they were also used for shunting purposes in Salzburg. At the DRG they were obviously very satisfied as well, as the locomotives was converted to a snowplough and it remained in service for many, many years.





HO

Maßstabs- und originalgetreue Kleinmodelle für erwachsene Sammler.

age
14+

Scale and true to original small-sized model for adult collectors.



Zum Betrieb des vorliegenden Produkts darf als Spannungsquelle nur ein nach VDE 0551/EN 60742 gefertigter Spielzeug-Transformator verwendet werden.

Only a toy transformer produced compliant with VDE 0551/EN 60742 may be used as a voltage source to operate this product.



Elektro- und Elektronikaltgeräte dürfen nicht in den Hausmüll gelangen. Sie müssen entsprechend der jeweils gültigen Länderrichtlinien fachgerecht entsorgt werden.



Electrical equipment may not reach to domestic waste. According to the current terms of the country reference the electrical equipment must professional disposed.

CE





Inhaltsverzeichnis Contents



Benennung	Seite
Allgemeine Montage- und Sicherheitshinweise	4
Entnahme der Lok aus der Verpackung	5
Arbeiten vor der Inbetriebnahme	6
Zusatzbauteile montieren	6
Wartungsarbeiten	
1. Ölen	7
2. Gehäuse demontieren	8
3. Beleuchtung, Platine tauschen	8
4. Motor tauschen	8
5. Digitaldecoder tauschen	8
6. Pantograph tauschen	8
7. Haftreifen tauschen	9
8. Schleifer tauschen bei Wechselstromausführung	9
9. Wartungsarbeiten an Radsätze und Getriebe	9
10. Umrüsten auf Digitalbetrieb	10
11. Umschalten von Unter- auf Oberleitung	10
Ersatzteilliste	
Gleichstrom- und Wechselstrom-Ausführung	12 – 13 / 14 – 15
Bestellbeispiel	15

Description	Page
General assembly and safety information	4
Removing the locomotive from the packaging	5
Work to be performed before starting up	6
Fitting additional parts	6
Maintenance works	
1. Lubricating	7
2. Dismantling the casing	8
3. Lightning, exchanging the motherboard	8
4. Exchanging the motor	8
5. Exchanging the digital decoder	8
6. Exchanging the pantograph	9
7. Exchanging traction wheels	9
8. Exchanging the pick-up in the AC version	9
9. Maintenance work on the wheel sets and gear	9
10. Converting to digital operation	10
11. Switching from subline to cat wire	10
Spare parts list	
Direct current and alternating current	12 – 13 / 14 – 15
Order example	15



Allgemeine Montage- und Sicherheitshinweise

- Diese Bedienungsanleitung beschreibt sämtliche Arbeitsvorgänge die zur Wartung und Instandhaltung notwendig sind. Bitte lesen Sie diese Bedienungsanleitung bevor Sie mit den Arbeiten beginnen.
- Bei unsachgemäßem Umgang mit elektrischen Bauteilen können diese zerstört werden. Für entsprechende Arbeiten (z. B. Platinenwechsel) können Sie sich an Ihren Fachhändler oder den Hersteller wenden.
- Bei den folgenden Wartungsarbeiten ist die jeweilige Demontage beschrieben, der Zusammenbau ist in umgekehrter Reihenfolge auszuführen.
- Die folgenden Wartungsarbeiten sind bei Gleich- und Wechselstrom-Ausführungen fast identisch. Im Ausnahmefall wird im entsprechenden Textabschnitt Bezug genommen.
- Jegliche Kabel oder Verbindungsdrähte die in diesem Produkt verbaut sind dürfen nicht in eine Netzsteckdose eingeführt werden. Lebensgefahr!

General assembly and safety information

- These operating instructions describe all work steps necessary for maintenance and repair. Please read these operating instructions carefully before you start with your work.
- In the case of incorrect handling of electrical components, they may be destroyed. Please ask your specialist dealer to help with the necessary work (e.g. changing circuit boards).
- In the case of maintenance work, the disassembly is described below, to re-assemble the tractor reverse the work steps.
- The maintenance work described below is virtually identical for direct current and alternating current models. If there are any differences these will be pointed out specifically.
- All cables and connection wires installed in this product may not be inserted in a mains socket. Danger!

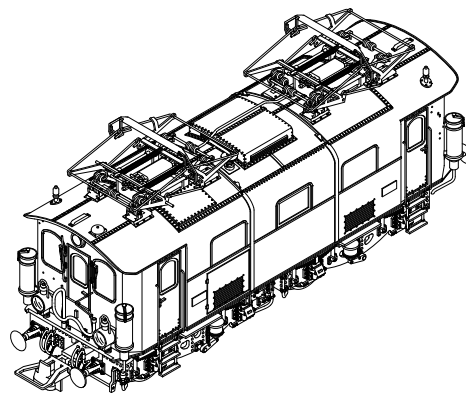



Entnahme der Lok aus der Verpackung (Fig. 1)

Deckel der Verpackung öffnen. Kunststoff-Schutzverpackung mit Lok entnehmen und auf einen Tisch oder ähnliches abstellen. Lasche (1) lösen, Deckel und Seitenteile der Schutzverpackung wegklappen, Lok entnehmen.

Withdrawal of Engine from Packaging (Fig. 1)

Open package lid. Take out plastics protecting package with engine and put it down on a table or similar item. Loosen latch (1), fold away lid and side parts of protecting package, take out engine and take out engine.

Fig. 1

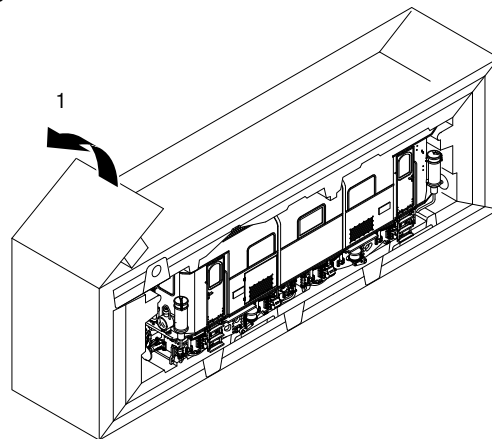



Arbeiten vor der Inbetriebnahme Work to be performed before starting up

Zusatzbauteile montieren (Fig. 2)

In der Verpackung sind zusätzliche Bauteile lose beigelegt.

- 1 = 2x Bügelkupplung
- 2 = 2x Kupplungshaken
- 3 = 2x Originalkupplung
- 4 = 8x Bremsschlauch Westinghouse
- 5 = 8x Bremsschlauch Knorr

Werden die Bauteile für Vitrinenmodelle montiert, ist die Lok nicht mehr für den Fahrbetrieb geeignet!

Fitting additional parts (Fig. 2)

Accessory parts have been loosely enclosed in the packaging.

- 1 = 2x Bow coupler
- 2 = 2x Coupler hook
- 3 = 2x Original coupling
- 4 = 8x Breaking hose Westinghouse
- 5 = 8x Breaking hose Knorr

If the components for display models are mounted, then the engine will no longer be suitable for operation!

Fig. 2

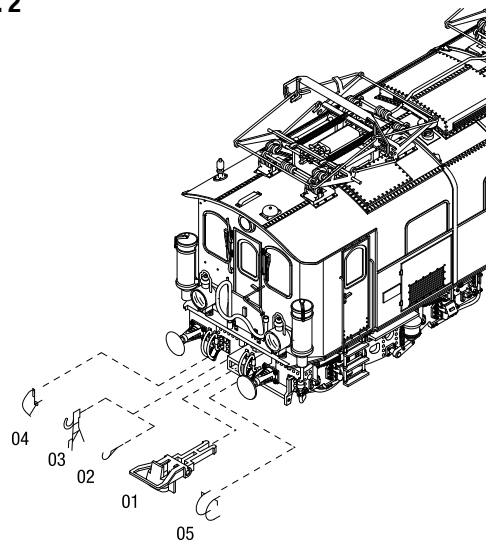



1. Ölen (Fig. 3)

Der Motor und die Lagerstellen der Radsätze können an den gekennzeichneten Punkten sparsam mit Öl der Modellbaubranche geölt werden. Zum Ölen des Motors ist das Gehäuse abzunehmen, siehe Seite 8 Punkt 2.

1. Lubricating (Fig. 3)

The engine and the wheelset bearings may be sparingly lubricated at the marked places with oil used for model making purposes. In order to lubricate the engine, remove the housing, compare page 8, item 2.

Fig. 3

Motor
Engine

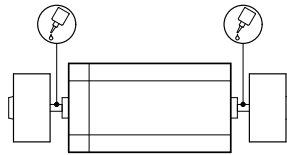

Räder
Wheels

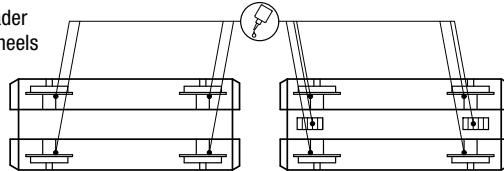



Wartungsarbeiten Maintenance works

2. Gehäuse demontieren (Fig. 5)

Schrauben (34) an der Gehäuseunterseite herausdrehen, Gehäuse (09) vorsichtig nach oben abnehmen.

2. Dismantling the casing (Fig. 5)

Unscrew the screws (34) on the underneath of the casing and lift the casing (09) up carefully.

3. Beleuchtung, Platine tauschen (Fig. 5)

Diese Lokomotive ist mit wartungsfreien Leuchtdioden ausgestattet (67, 68). Bei einem eventuellen Defekt der Leuchtdioden wenden Sie sich bitte an Ihren Fachhändler oder den Hersteller. Befestigungsschraube (80) herausdrehen. Sämtliche Kabelschuhe (60) von der Platine (59) abnehmen. Bitte kennzeichnen Sie sich wo die einzelnen Kabel angebracht waren. Platine nach oben abnehmen.

3. Lighting, exchanging the motherboard (Fig. 5)

This locomotive is fitted with maintenance-free light-emitting diodes (67, 68). If a defect occurs in the light-emitting diodes, please contact your specialist dealer or the manufacturer. Unscrew attachment screws (80). Remove all abellugs (60) from the motherboard (59). Please note where the individual cables were attached. Lift out motherboard.

4. Motor tauschen (Fig. 5)

Gehäuse abnehmen, siehe Punkt 2.
Schrauben (31) an der Gehäuseunterseite herausdrehen und Motor (30) nach oben herausnehmen.



Achtung!

Bei Ausbau des Motors auf Einbaulage achten – sonst falsche Fahrtrichtung.



4. Exchanging the motor (Fig. 5)

Remove casing, see point 2.
Unscrew the screws (31) on the underneath of the casing and remove the motor (30).

Warning!

Please note the installation position of the motor when removing, otherwise wrong direction of motion.

5. Digitaldecoder tauschen (Fig. 5)

Gehäuse abnehmen, siehe Punkt 2. Digitaldecoder (69) abziehen und neuen einstecken.

5. Exchanging the digital decoder (Fig. 5)

Remove casing, see point 2. Pull out digital decoder (69) and insert new unit.

6. Pantograph tauschen (Fig. 5)

Gehäuse abnehmen, siehe Punkt 2. Befestigungsschraube (66) im Gehäuseinneren herausdrehen und Pantograph (01) vorsichtig vom Isolator trennen und abnehmen. Beim Einbau des Pantographen und festziehen der Befestigungsschraube ist darauf zu achten, dass sich das Kontaktblech auf der Platine (67, 68) nicht verdreht.





6. Exchanging the pantograph (Fig. 5)

Remove casing, see point 2. Unscrew attachment screw (66) on the inside of the casing and carefully separate the pantograph (01) from the isolator and remove. When installing the pantograph and tightening the attachment screw, please ensure that the contact plate on the pcb (67, 68) is not twisted.

7. Haftreifen tauschen (Fig. 5)

Gehäuse abnehmen, siehe Punkt 2.
Drehgestellhalter (32) mit kleinem Schraubendreher ausclippen.
Schnecke (33) mit Kardanwelle aus Halterung entfernen. Drehgestell (48) nach unten abnehmen und Haftreifen (77) tauschen.

7. Exchanging traction wheels (Fig. 5)

Remove casing, see point 2.
Unclip bogie holder (32) with a small screwdriver. Remove the worm gear (33) with cardan shaft from the holder. Remove bogie (48) downwards and exchange traction wheels (77).

8. Schleifer tauschen bei Wechselstromausführung (Fig. 5)

Befestigungsschraube (58) des Schleifers (57) herausdrehen und Schleifer abnehmen.

8. Exchanging the pick-up in the AC version (Fig. 5)

Unscrew the attachment screw (58) of the pick-up (57) and remove pick-up.



9. Wartungsarbeiten an Radsätze und Getriebe (Fig. 5)

Bei Wartungsarbeiten an den Radsätzen und dem Getriebe muss das gesamte Fahrgestell zerlegt werden. Wir bitten Sie bei der Demontage des Fahrgestells genau darauf zu achten, wo und wie jedes Einzelteil montiert war.

Die Einbaulage können Sie auch aus der Ersatzteilgrafik Seite 12 und 13 ersehen. Vor dem Zerlegen des Fahrgestells muss das Gehäuse demontiert werden (siehe Punkt 2). Für Beschädigungen, die durch unsachgemäße Arbeiten an den Bauteilen entstehen, kann die Firma BRAWA nicht haftbar gemacht werden.

9. Maintenance work on the wheel sets and gears (Fig. 5)

When performing maintenance work on the wheel sets and the gears, the whole chassis must be dismantled. We would remind you to note exactly where and how each part was assembled before dismantling the chassis.

The installation position can be seen in the spare parts chart on pages 12 and 13. Before dismantling the chassis, the casing must be removed (see point 2). BRAWA is not liable for damage which occurs due to improper work on construction parts.





Wartungsarbeiten Maintenance works

10. Umrüsten auf Digitalbetrieb

Gleichstrom-Ausführung

Dach abnehmen, Blindstecker (81) abziehen und Digital-Decoder (69) einstecken. Den richtigen Einbau des Digitaldecoders und dessen Einsteckrichtung entnehmen Sie der Einbauvorschrift des Decoder-Herstellers.

Wechselstrom-Ausführung

Lokomotiven in Wechselstrom-Ausführung AC werden serienmäßig mit Premium-Digitaldecoder (69) ausgeliefert. Der Decoder erkennt die Betriebsart (analog / digital) selbstständig. Soll der Decoder umprogrammiert werden, liegt die Einbau- und Betriebsanleitung Premium-Digitaldecoder bei.

Der Decoder ist werkseitig auf Adresse 03 eingestellt.

10. Converting to digital operation

DC version

Remove roof, pull off dummy connector (81) and insert digital decoder (69). Please consult the installation instructions issued by the decoder manufacturer for correct installation of the digital decoder and its insert direction.

AC version

The premium digital decoder (69) is standard for the alternating current (AC) locomotives models. The decoder independently identifies the operation type (analogue/digital). Please refer to the enclosed installation and operation instructions "Premium Digital Decoder" in the event that the decoder needs to be reprogrammed.

The decoder is set to address 03 in the factory.

11. Umschalten von Unter- auf Oberleitung (Fig. 4)

Die E-Lok wird für Unterleitungsbetrieb geliefert!

Dachaufsatz (08) abnehmen. Für Oberleitungsbetrieb muß der Schalter auf der Platine um 90° nach rechts gedreht werden.

11. Switching from subline to cat wire (Fig. 4)

The electric locomotive is supplied for subline operation!

Remove the roof (08). For cat wire operation turn the switch on the pc-board by 90° to the right.

Fig. 4

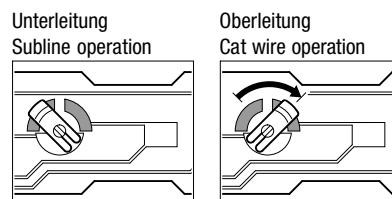
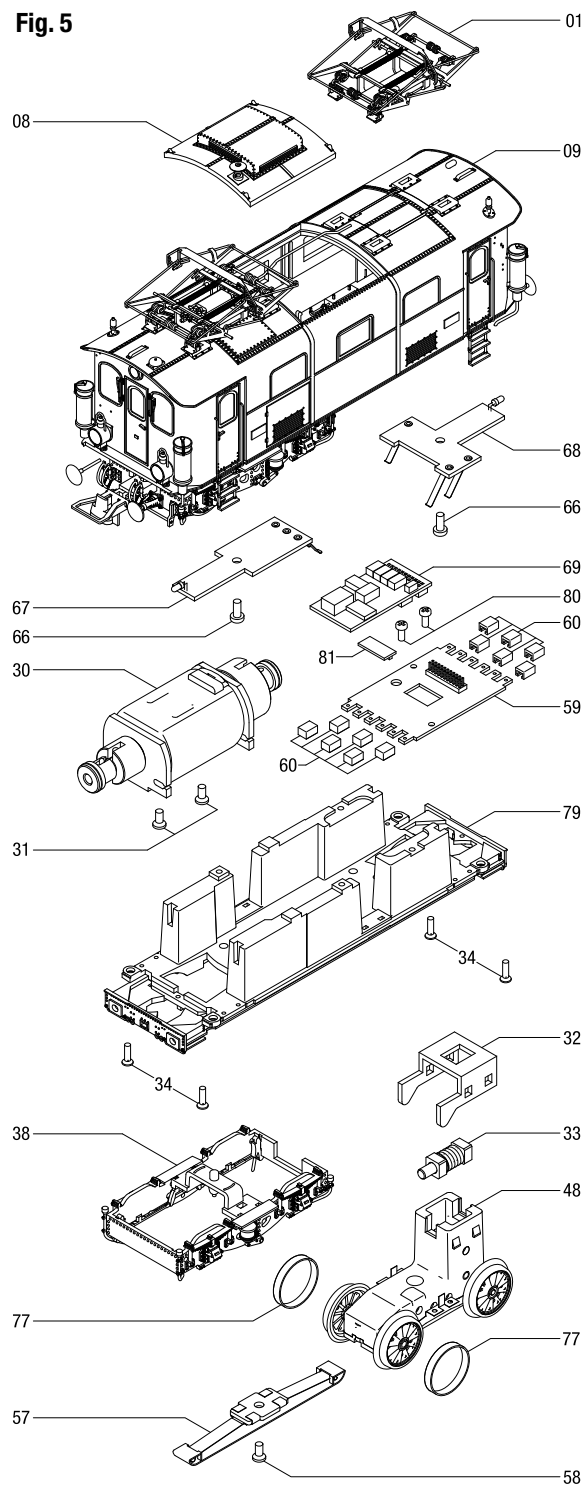

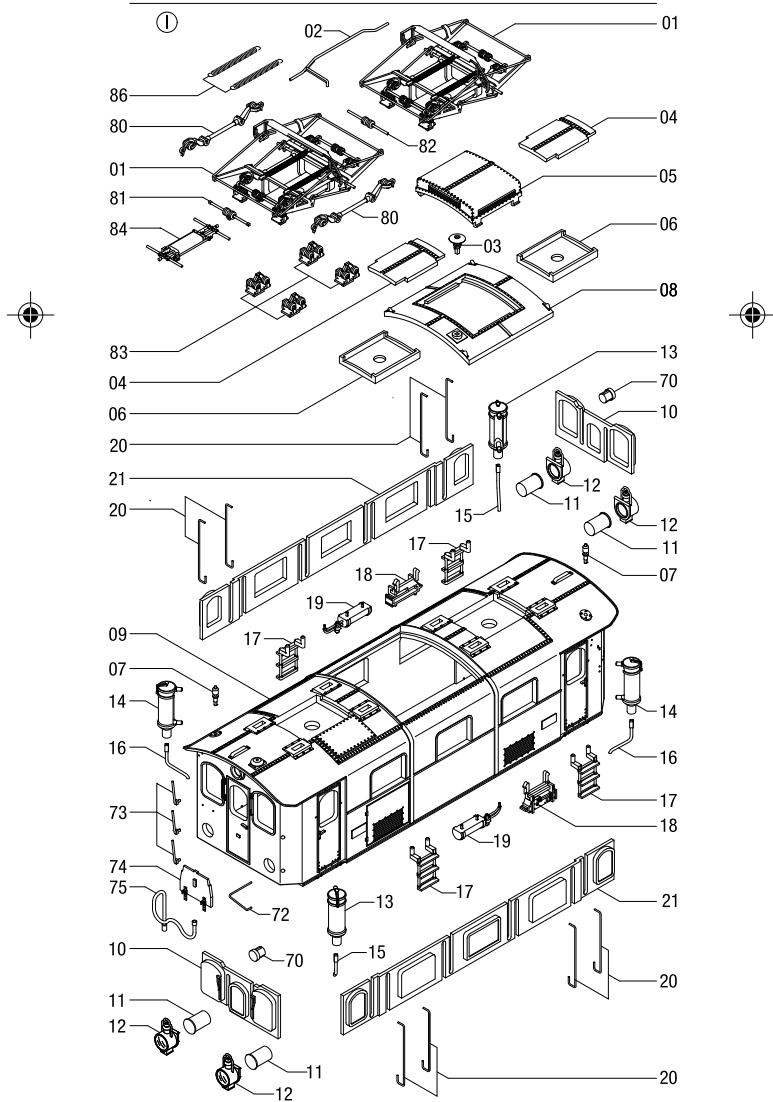
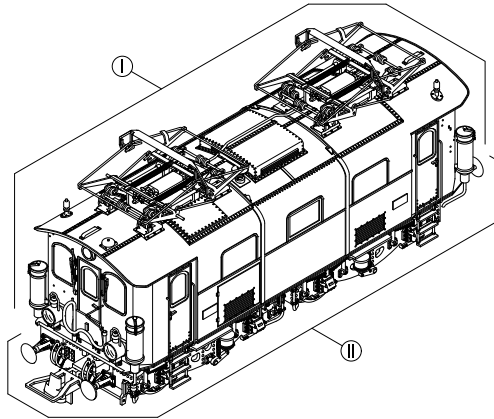

Fig. 5





Ersatzteilliste Spare parts list



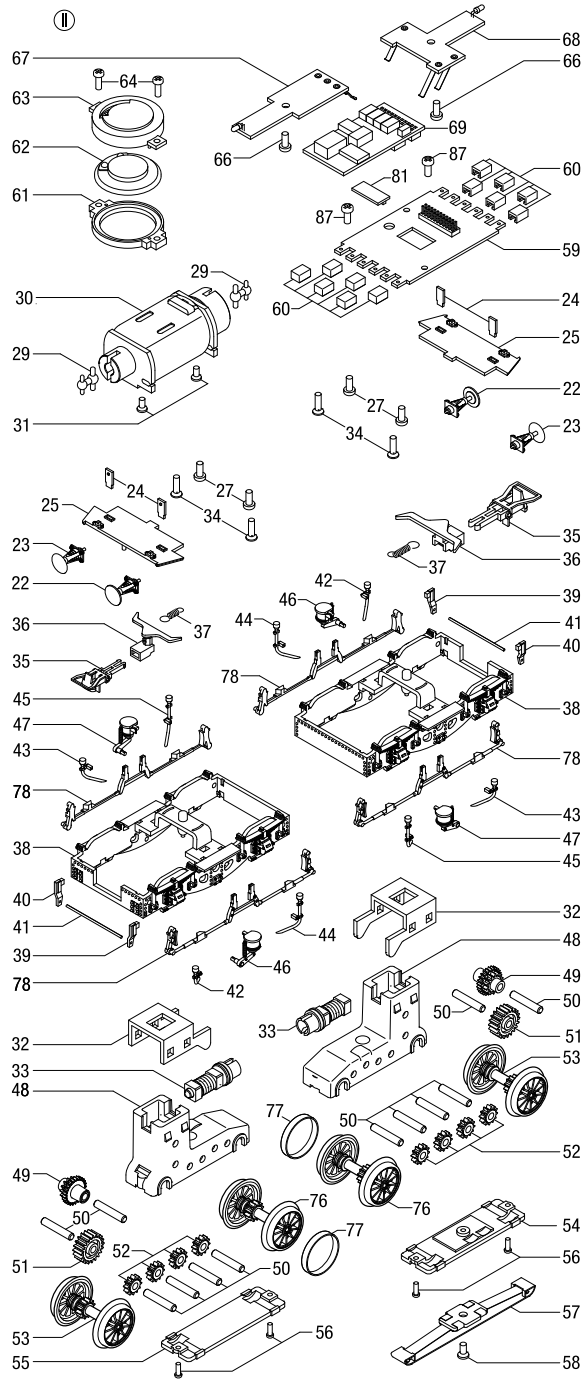



Ersatzteilliste Spare parts list

Pos.	Bestell Nr. Order no.	Benennung	Description
1	43054.50.01	Pantograph	Pantograph
2	43050.50.02	Dachleitung	Roof wire
3	43050.50.03	Schraube	Screw
4	43054.50.04	Abdeckung	Cover
5	43054.50.05	Abdeckung	Cover
6	43050.50.06	Halter f. Phantogr.	Holder f. pantogr.
7	43050.50.07	Pfeife	Pipe
8	43054.50.08	Dachaufsatz	Roof
9	43066.50.09	Gehäuse	Body
10	43050.50.10	Fenstereinsatz vorne	Window front
11	43050.50.11	Lichtleiter	Light bar
12	43050.50.12	Lampe	Lamp
13	43054.50.13	Sandbehälter li.	Sand box le.
14	43054.50.14	Sandbehälter re.	Sand box ri.
15	43050.50.15	Sandrohr li.	Sandpipe le.
16	43050.50.16	Sandrohr re.	Sandpipe ri.
17	43050.50.17	Leiter	Ladder
18	43050.50.83	Hebewinde	Winch
19	43050.50.18	Luftkessel	Airtank
20	43054.50.19	Griffstange	Handrail
21	43050.50.20	Fenstereinsatz	Window
22	43050.50.21	Puffer li.	Buffer le.
23	43050.50.22	Puffer re.	Buffer ri.
24	43050.50.23	Platine m. LED	PCB w. LED
25	43050.50.24	Abdeckung	Cover
27	43050.50.26	Schraube	Screw
29	43050.50.28	Kardan	Cardan
30	43050.50.29	Motor kpl. mit Halterung	Motor cpl. w. holder
31	43050.50.30	Schraube f. Motor	Screw f. motor
32	43050.50.31	Halter f. Drehgestell	Holder f. bogie
33	43050.50.32	Schnecke kpl.	Worm gear cpl.
34	43050.50.33	Schraube Gehäuse	Screw body
35	9952.50.03	Kupplung	Coupler
36	43050.50.34	Kupplungsdeichsel	Coupler pocket
37	43050.50.35	Feder	Spring
38	43050.50.36	Drehgestellblende	Bogie frame
39	43050.50.37	Schienenräumer li.	Track cleaner le.
40	43050.50.38	Schienenräumer re.	Track cleaner ri.
41	43050.50.39	Schienenräumerverbindung	Track cleaner
42	43050.50.40	Sandfallrohr vorne li.	Sandpipe front le.
43	43050.50.41	Sandfallrohr vorne re.	Sandpipe front ri.
44	43050.50.42	Sandfallrohr mitte li.	Sandpipe middle le.
45	43050.50.43	Sandfallrohr mitte re.	Sandpipe middle ri.
46	43050.50.44	Bremszylinder li.	Brake cylinder le.
47	43050.50.45	Bremszylinder re.	Brake cylinder ri.
48	43050.50.46	Getriebegehäuse	Gearbox
49	43050.50.47	Zahnrad f. Schnecke	Gear f. worm
50	43050.50.48	Zahnradwelle	Gear shaft
51	43050.50.49	Zahnrad 1	Gear 1
52	43050.50.50	Zahnrad 2	Gear 2
53	43054.50.51	Radsatz DC	Wheelset DC
	43055.50.51	Radsatz AC	Wheelset AC
54	43050.50.52	Getriebeabdeckung DC	Gearbox cover DC
	43051.50.52	Getriebeabdeckung AC	Gearbox cover AC
55	43050.50.53	Getriebeabdeckung	Gearbox cover
56	43050.50.54	Schraube f. Getriebeabdeck.	Screw f. gearbox cover
57	2225	Schleifer AC	Pic up shoe AC
58	43051.50.55	Schraube f. Schleifer	Screw f. pic up shoe
59	43066.50.56	Platine	PCB





Pos.	Bestell Nr. Order no.	Benennung	Description
60	0250.55.83	Kabelschuh	Cabellug
61	43050.50.01	Halterung f. Lautsprecher	Holder f. speaker
62	9750.51.98	Lautsprecher	Speaker
63	43050.50.03	Schallkapsel	Sound cap
64	43050.50.04	Schraube	Screw
66	43050.50.58	Schraube	Screw
67	43050.50.59	Platine 1 f. Stirnlampe	PCB 1 f. top light
68	43050.50.60	Platine 2 f. Stirnlampe	PCB 2 f. top light
69	9750.50.84	Digital Premium Decoder	Digital Premium Decoder
	9750.50.86	Sounddecoder 21-pol.	Sounddecoder 21-pol.
70	43050.50.61	Lichtleiter Stirnlampe	Light bar top light
71	0000749.00	Zurüstbeutel	Add on part
72	43054.50.20	Griffstange	Handrail
73	43054.50.21	Halter f. Trittstufe	Step support
74	43054.50.22	Übergang	Walkway
75	43054.50.23	Leitung	Pipe
76	43054.50.63	Radsatz mit Haftreifennut DC	Wheelset w. traction tire DC
	43055.50.63	Radsatz mit Haftreifennut AC	Wheelset w. traction tire AC
77	43050.50.64	Haftreifen	Traction tire
78	43050.50.65	Bremseinrichtung	Brake block unit
80	43050.50.67	Strebe	Strives
81	43050.50.68	Querstrebe	Tie bar
82	43050.50.69	Querstrebe	Tie bar
83	43050.50.70	Isolator	Isolator
84	43054.50.71	Abdeckung	Cover
86	43050.50.73	Feder für Pantograph	Spring for pantograph
87	43050.50.81	Schraube für Platine	Screw for PCB
88	43050.50.82	Blindstecker 21-pol.	Blind plug 21-pol.



Wichtiger Hinweis!

Bei der Bestellung von Ersatzteilen muss die Bestell-Nr. und die Benennung angegeben werden. Ist dies nicht der Fall, kann die Bestellung nicht bearbeitet werden.

Bestellbeispiel:

Position (30), Motor kpl. mit Halterung = 43050.50.25, Motor kpl. mit Halterung

Important notice!

When ordering spare parts you must always state the order number and give the description. If you do not do this, the order cannot be processed.

Order example:

Position (30), Motor cpl. w. holder = 43050.50.25, Motor cpl. with holder





Brawa Artur Braun Modellspielwarenfabrik GmbH & Co.
Uferstraße 26-28 · D-73630 Remshalden
Hotline 07151 - 979 35 68
Telefax 07151 - 746 62
<http://www.brawa.de>

43066.50.80 / 07 11 - BRA

